

GENERAL

Attachment clips are attached to the pin housings of some connectors. The clips are then attached to T-studs on the motorcycle frame. T-studs give positive location to electrical connectors and wire harnesses. Consistent location reduces electrical problems and improves serviceability.

To become familiar with the Deutsch connector, read the parts description below while referencing the 12-place connector illustrated in [Figure B-3](#).

Socket housing: alignment tabs and/or external latch, secondary locking wedge, internal seal, wire seal, seal pin.

NOTE

Seal pins or plugs are installed in the wire seals of unused chambers. If removed, seal pins must be replaced to maintain the integrity of the environmental seal.

Pin housing: alignment grooves and/or external latch cover, secondary locking wedge, wire seal, seal pin.

REMOVING/DISASSEMBLING

1. Push the connector to disengage small end of slot on attachment clip from T-stud. Lift connector off T-stud.
2. Depress the external latch(es) on the socket housing side and use a rocking motion to separate the pin and socket halves. Two-, three-, four- and six-place Deutsch connectors have one external latch, while eight- and twelve-place connectors have two, both of which must be pressed simultaneously to separate the connector halves.

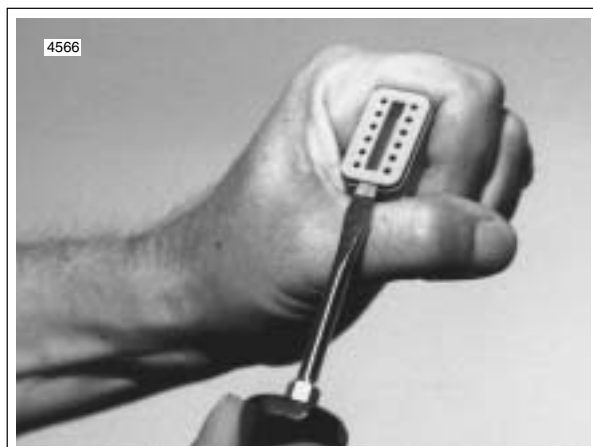

Figure B-1. Remove Secondary Locking Wedge

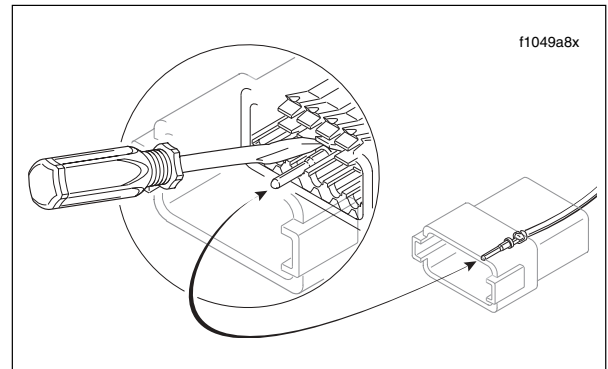

Figure B-2. Depress Terminal Latches/Back Out Pins

NOTE

With few exceptions, the socket housing can always be found on the accessory side, while the pin side of the connector is plumbed to the wiring harness.

REMOVING/INSTALLING SOCKETS

1. See [Figure B-1](#). Remove the secondary locking wedge. Insert the blade of a small screwdriver between the socket housing and locking wedge inline with the groove (inline with the pin holes if the groove is absent). Turn the screwdriver 90 degrees to pop the wedge up.
2. Gently depress terminal latches inside socket housing and back out sockets through holes in rear wire seal. See [Figure B-2](#).

NOTE

If new terminals must be installed, see [CRIMPING INSTRUCTIONS](#) in this section.

3. Fit rear wire seal into back of socket housing, if removed. Grasp socket approximately 1 inch (25.4 mm) behind the contact barrel. Gently push sockets through holes in wire seal into their respective chambers. Feed socket into chamber until it “clicks” in place. Verify that socket will not back out of chamber; a slight tug on the wire will confirm that it is properly locked in place.
4. Install internal seal on lip of socket housing, if removed. Insert tapered end of secondary locking wedge into socket housing and press down until it snaps in place. The wedge fits into the center groove within the socket housing and holds the terminal latches tightly closed.

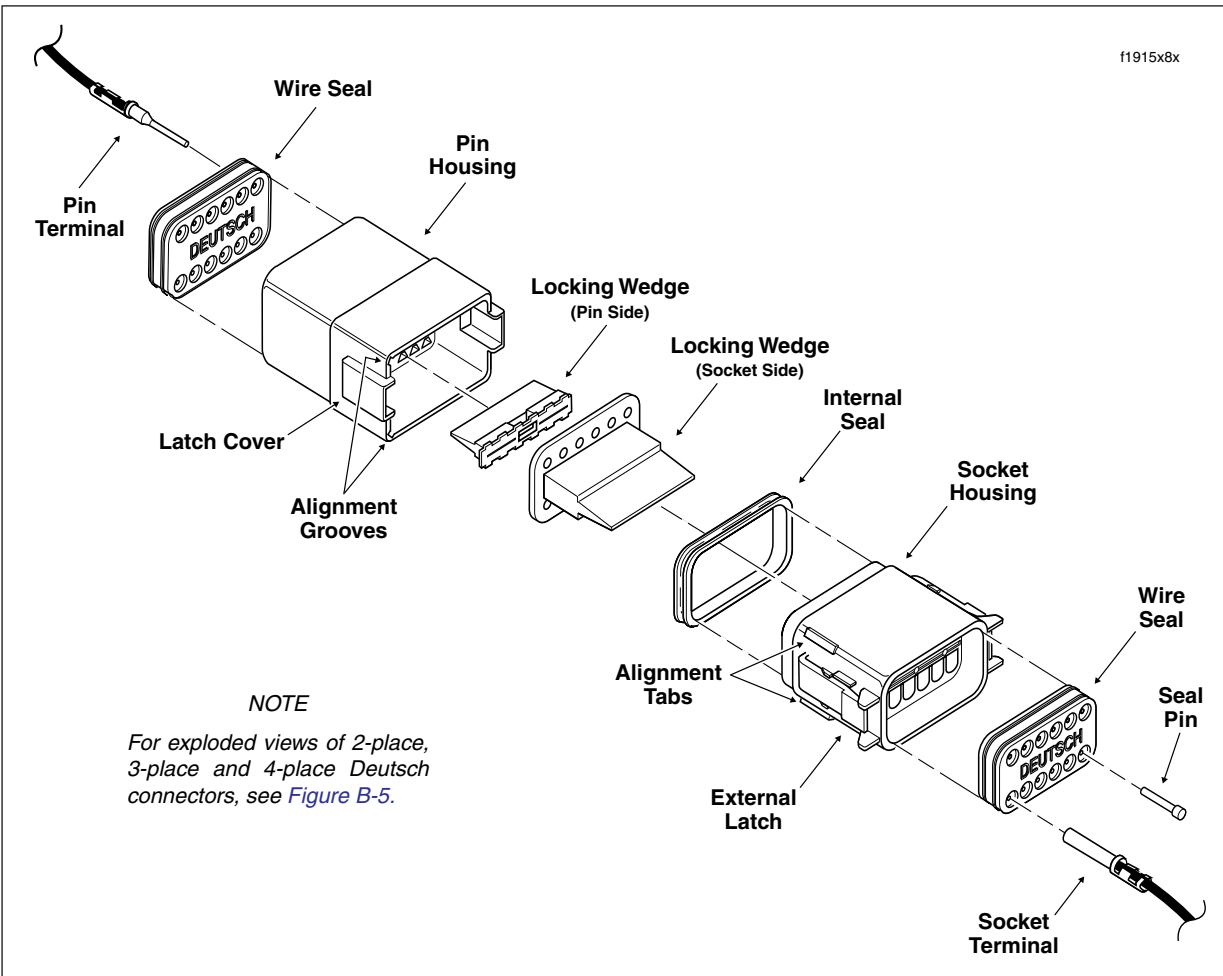

Figure B-3. 12-Place Deutsch Connector (Exploded View)

NOTE

While rectangular wedges do not require a special orientation, the conical secondary locking wedge of the 3-place connector must be installed with the arrow pointing toward the external latch. See [Figure B-4](#).

NOTE

If the secondary locking wedge does not slide into the installed position easily, verify that all terminals are fully installed in the socket housing. The lock indicates when terminals are not properly installed by not entering its fully installed position.

REMOVING/INSTALLING PINS

1. Remove the secondary locking wedge. Use the hooked end of a stiff piece of mechanics wire, a needle nose pliers or a suitable pick tool (HD-41475-100). See [Figure B-6](#).

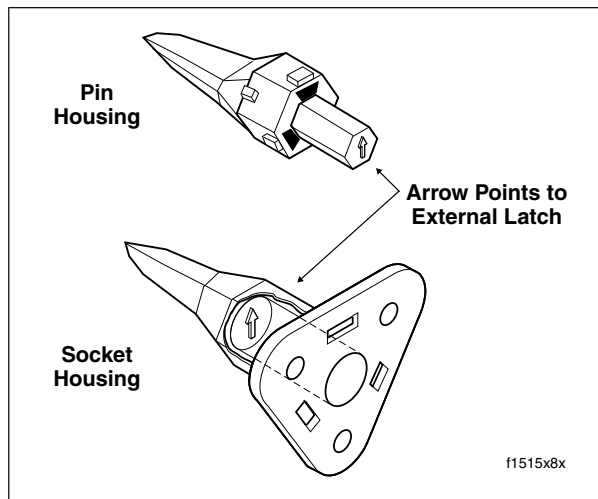

Figure B-4. 3-Place Locking Wedge Orientation

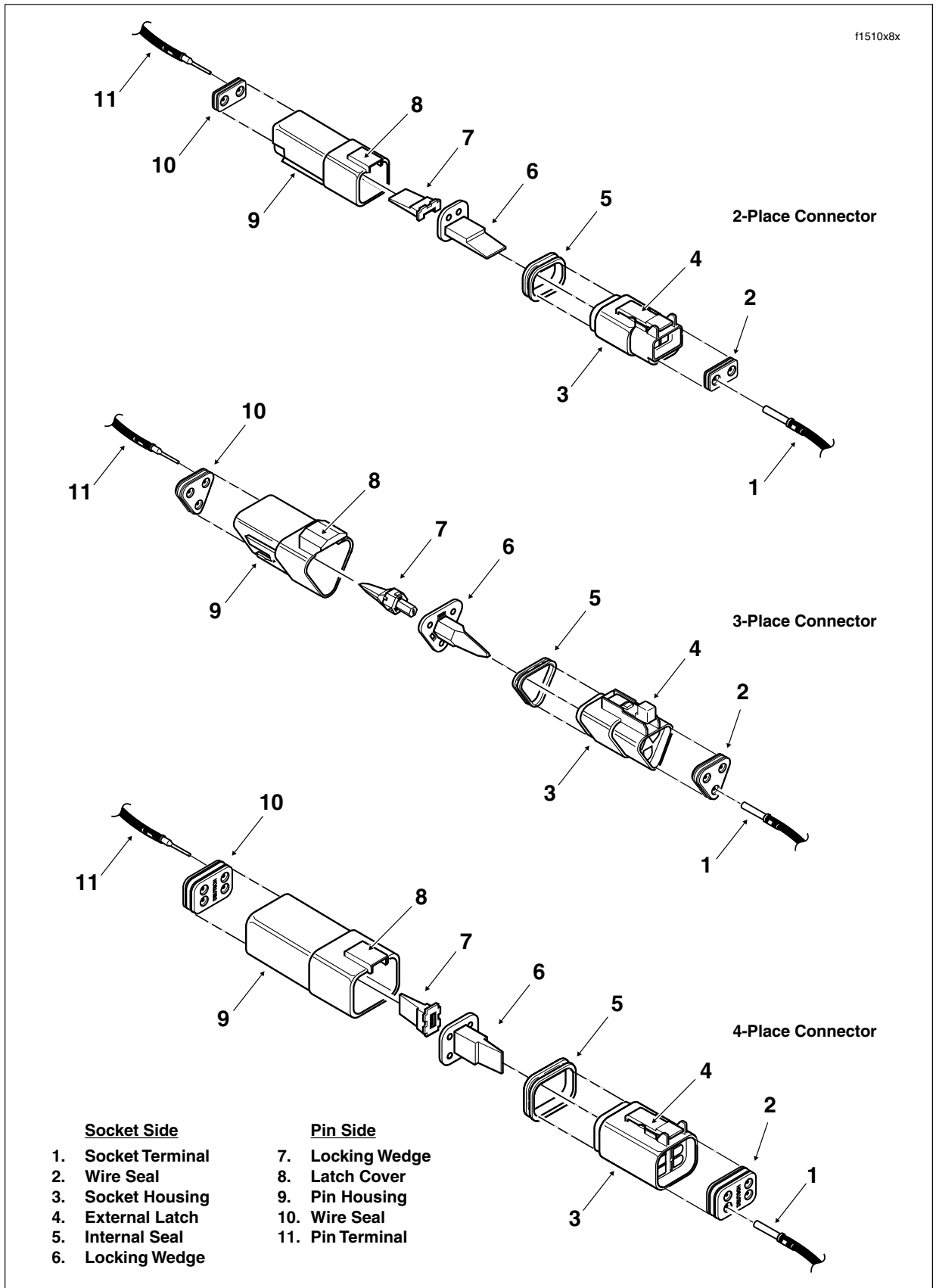
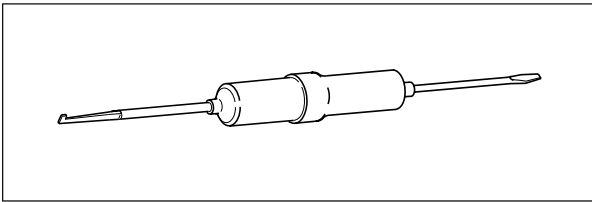

Figure B-5. 2-Place, 3-Place and 4-Place Deutsch Connectors



**Figure B-6. Deutsch Connector Pick Tool
(Part No. HD-41475-100)**

2. Gently depress terminal latches inside pin housing and back out pins through holes in wire seal.

NOTE

If new terminals must be installed, see [CRIMPING INSTRUCTIONS](#) on this page.

3. Fit wire seal into back of pin housing. Grasp crimped pin approximately 1 inch (25.4 mm) behind the contact barrel. Gently push pins through holes in wire seal into their respective numbered locations. Feed pin into chamber until it “clicks” in place. Verify that pin will not back out of chamber; a slight tug on the wire will confirm that it is properly locked in place.
4. Insert tapered end of secondary locking wedge into pin housing and press down until it snaps in place. The wedge fits in the center groove within the pin housing and holds the terminal latches tightly closed.

NOTE

While rectangular wedges do not require a special orientation, the conical secondary locking wedge of the 3-place connector must be installed with the arrow pointing toward the external latch. See [Figure B-4](#).

NOTE

If the secondary locking wedge does not slide into the installed position easily, verify that all terminals are fully installed in the pin housing. The lock indicates when terminals are not properly installed by not entering its fully installed position.

ASSEMBLING/INSTALLING

1. Insert socket housing into pin housing until it snaps in place. Two-, three-, four- and six-place Deutsch connectors have one external latch on the socket half of the connector. To fit the halves of the connector together, the latch on the socket side must be aligned with the latch cover on the pin side.

For those connectors with two external latches (8-place and 12-place), a different system is used to prevent improper assembly. Align the tabs on the socket housing with the grooves on the pin housing. Push the connector halves together until the latches “click.” If latches do not

click (latch), press on one side of the connector until that latch engages, then press on the opposite side to engage the other latch.

NOTES

- *Deutsch connectors are colored coded for location purposes. Those connectors associated with **left** side accessories, such as the front and rear **left** turn signals, are **gray**. All other connectors, including those associated with right side accessories, are **black**.*
 - *If it should become necessary to replace a plug or receptacle, please note that the 8-place and 12-place gray and black connectors are not interchangeable. Since location of the alignment tabs differ between the black and gray connectors, plugs or receptacles must be replaced by those of the same color. If replacing both the socket and pin halves, then the black may be substituted for the gray, and vice versa. The socket and pin halves of all other connectors are interchangeable, that is, the black may be mated with the gray, since the alignment tabs are absent and the orientation of the external latch is the same.*
2. Fit the attachment clip to the pin housing, if removed. Place large end of slot on attachment clip over T-stud on frame. Push assembly forward to engage small end of slot.

CRIMPING INSTRUCTIONS

Use the Deutsch Terminal Crimp Tool (HD-39965) to install standard size terminals with crimp tails, as described under [STANDARD TERMINALS](#) below. To install the mini-Deutsch terminals with crimp tails, see [MINI TERMINALS](#), which follows. To install those terminals without crimp tails, both standard and mini-Deutsch, use the Deutsch Solid Barrel Contact Crimp Tool (HD-42879) as described under [SOLID BARREL CONTACTS](#).

NOTE

A *Deutsch Connector Service Kit (HD-41475)* contains a selection of wire seals, internal seals, seal plugs, secondary locking wedges, attachment clips and socket/pin terminals. Also included is a compartmented storage box, carrying case and pick tool (HD-41475-100) used for the removal of all types of locking wedges.

STANDARD TERMINALS

1. Obtain the DEUTSCH TERMINAL CRIMP TOOL (HD-39965).
2. Squeeze the handles to cycle the crimp tool to the fully open position. See [Figure B-7](#).

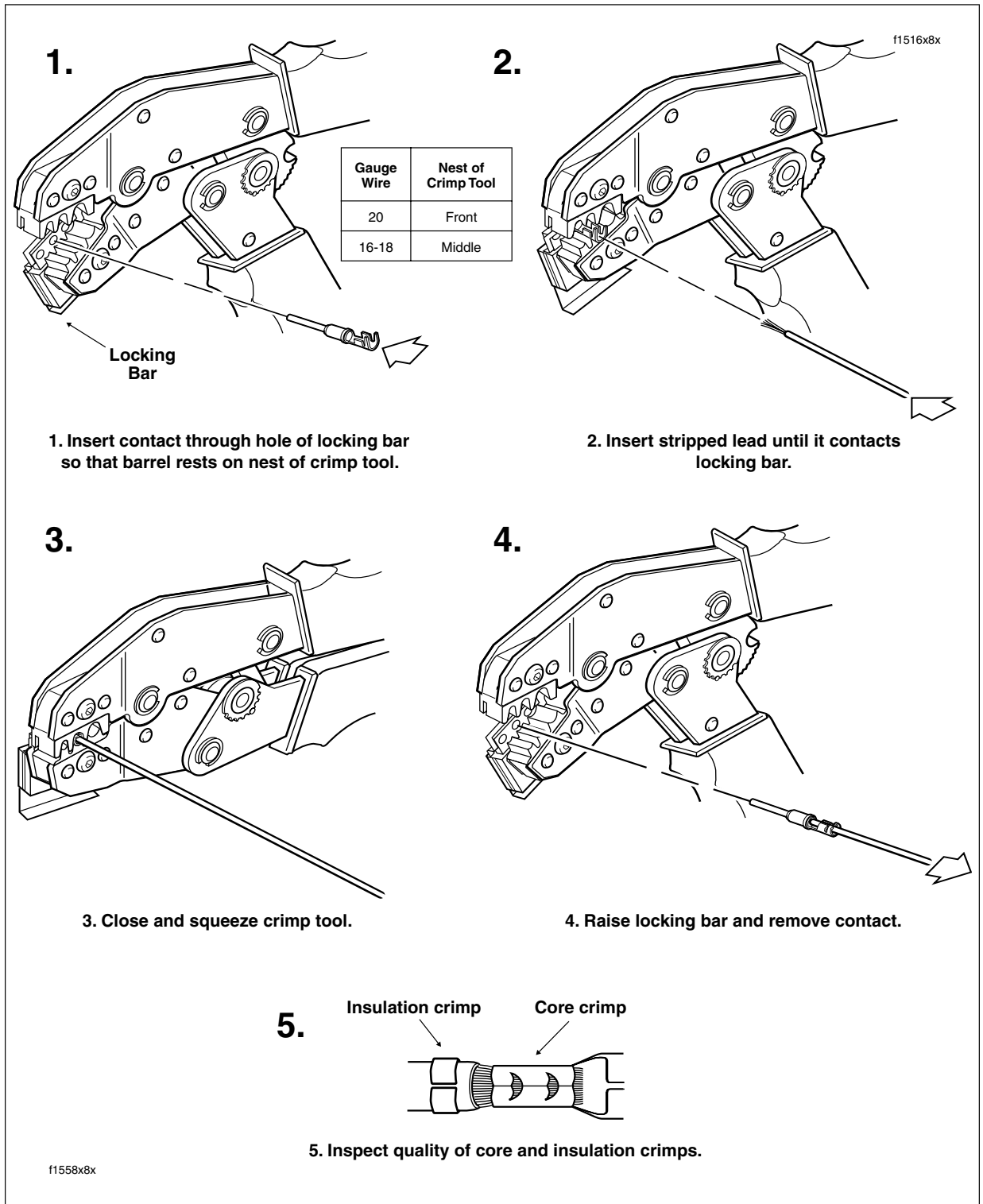

Figure B-7. Deutsch Crimping Procedure

3. Raise the locking bar by pushing up on bottom flange. With the crimp tails facing upward, insert contact (socket/pin) through hole of locking bar, so that the rounded side of the contact barrel rests on the nest (concave split level area) of the crimp tool. Use the middle hole in the locking bar for 16-18 gauge wire, the front hole for 20 gauge wire.
4. Release locking bar to lock position of contact. If the crimp tails are slightly out of vertical alignment, the crimp tool automatically rotates the contact so that the tails face straight upward. When correctly positioned, the locking bar fits snugly in the space between the contact band and the core crimp tails.
5. Strip lead removing 5/32 inch (4.0 mm) of insulation. Insert wires between crimp tails until ends make contact with locking bar. Verify that wire is positioned so that short pair of crimp tails squeeze bare wire strands, while long pair folds over insulation material.
6. Squeeze handle of crimp tool until tightly closed. Tool automatically opens when the crimping sequence is complete. Raise up locking bar and remove contact.
7. Inspect the quality of the core and insulation crimps. Distortion should be minimal.

MINI TERMINALS

1. Obtain the PACKARD TERMINAL CRIMP TOOL (HD-38125-7).
2. Strip wire lead removing 5/32 inch (4.0 mm) of insulation.
3. Compress handles until ratchet automatically opens.

NOTE

Always perform core crimp before insulation crimp.

4. Position the core crimp on nest E of the crimping tool. Be sure the core crimp tails are facing the forming jaws.
5. Gently apply pressure to handles of tool until crimpers just secure the core crimp tails.
6. Insert stripped wire between crimp tails. Verify that wire is positioned so that short pair of crimp tails squeeze bare wire strands, while long pair is positioned over the insulation material.
7. Squeeze handle of crimp tool until tightly closed. Tool automatically opens when the crimping sequence is complete.
8. Position the insulation crimp on nest C of the crimping tool. Be sure the insulation crimp tails are facing the forming jaws.
9. Squeeze handle of crimp tool until tightly closed. Tool automatically opens when the crimping sequence is complete.
10. Inspect the quality of the core and insulation crimps. Distortion should be minimal.

SOLID BARREL CONTACTS

For Size 20, 16 and 12 Contacts

Wire Range 26-12 AWG

1. Obtain the DEUTSCH SOLID BARREL CONTACT CRIMP TOOL (HD-42879).
2. Squeeze the handles to cycle the crimp tool to the fully open position.
3. Remove locking pin from selector knob. See [Figure B-8](#).
4. Raise selector knob and rotate until selected wire size stamped on wheel is aligned with "SEL. NO." arrow. See upper frame of [Figure B-9](#).
5. Loosen knurled locknut and turn adjusting screw clockwise (in) until it stops.
6. Turn tool over and drop contact into indenter cover hole with the wire end out.
7. Turn adjusting screw counterclockwise (out) until contact is flush with bottom of depression in indenter cover. Tighten knurled locknut.
8. Slowly squeeze handles of crimp tool until contact is centered between indenter points. See middle frame of [Figure B-9](#).
9. Strip wire lead removing 1/4 inch (6.4 mm) of insulation.
10. Insert bare wire strands into contact barrel. See lower frame of [Figure B-9](#).
11. Squeeze handle of crimp tool until tightly closed. Tool automatically opens when the crimping sequence is complete.
12. Remove crimped contact from indenter.
13. Inspect the quality of the crimp. Verify that all wire strands are in crimp barrel.

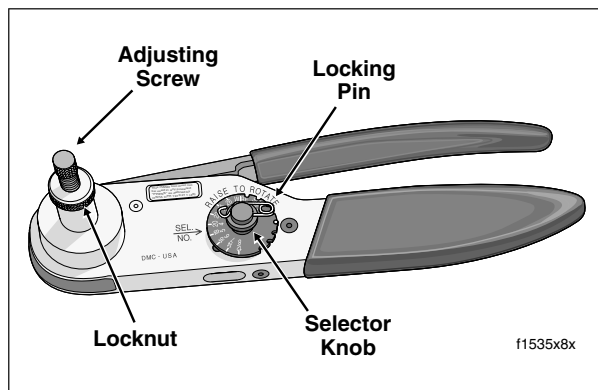
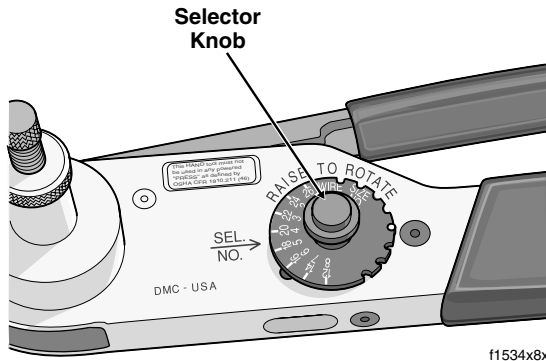
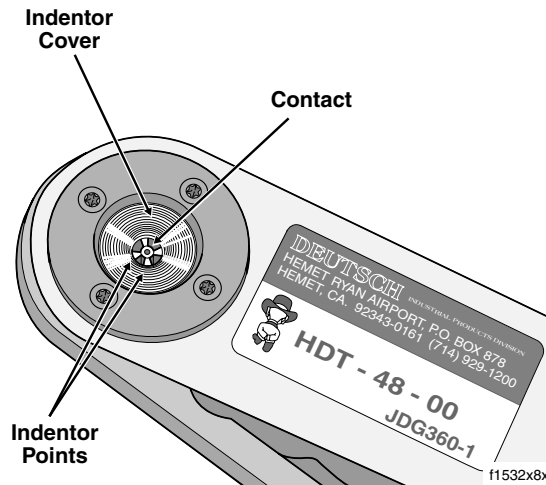

Figure B-8. Deutsch Solid Barrel Contact Crimp Tool (Part No. HD-42879)

Rotate selector knob to align wire size on wheel with arrow stamped in tool.



Turn adjusting screw as described in text. When contact is flush with bottom of depression in indenter cover, squeeze handles to center contact between indenter points.



Insert bare wire strands into contact barrel. Squeeze handle of crimp tool until tightly closed.

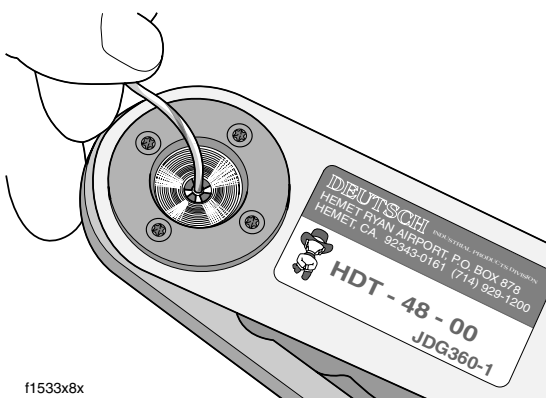

Figure B-9. Deutsch Solid Barrel Contact Crimping Procedure

NOTE

Tool must be readjusted when changing contact size/type.

14. Install pin to lock position of selector knob.

REMOVING SOCKET/PIN TERMINALS

1. Remove connector from the retaining device, either attachment or rosebud clip.
2. Depress the button on the socket terminal side of the connector (plug) and pull apart the pin and socket halves. See [Figure B-10](#).
3. Bend back the latch slightly and free one side of secondary lock, then repeat the step to release the other side. Rotate the secondary lock outward on hinge to access terminals in chambers of connector housing.
4. Looking in the terminal side of the connector (opposite the secondary lock), take note of the cavity next to each terminal.
5. See [Figure B-11](#). With the flat edge against the terminal, insert the pick (Snap-On TT600-3) into the cavity until it stops. Pivot the end of the pick away from the terminal and gently tug on wire to pull terminal from chamber. Do not tug on the wire until the tang is released or the terminal will be difficult to remove. A "click" is heard if the tang

is engaged but then inadvertently released. Repeat the step without releasing the tang.

NOTE

An *Electrical Terminal Crimp Tool* (Part No. HD-41609) is used to install Multilock pin and socket terminals on wires. If new terminals must be installed, see [CRIMPING INSTRUCTIONS](#) in this section.

INSTALLING SOCKET/PIN TERMINALS

NOTE

For wire location purposes, numbers are stamped into the secondary locks of both the socket and pin housings. See [Figure B-13](#).

1. From the secondary lock side of the connector, insert the terminal into its respective numbered chamber until it snaps in place. For proper fit, the slot in the terminal must face the tang in the chamber.

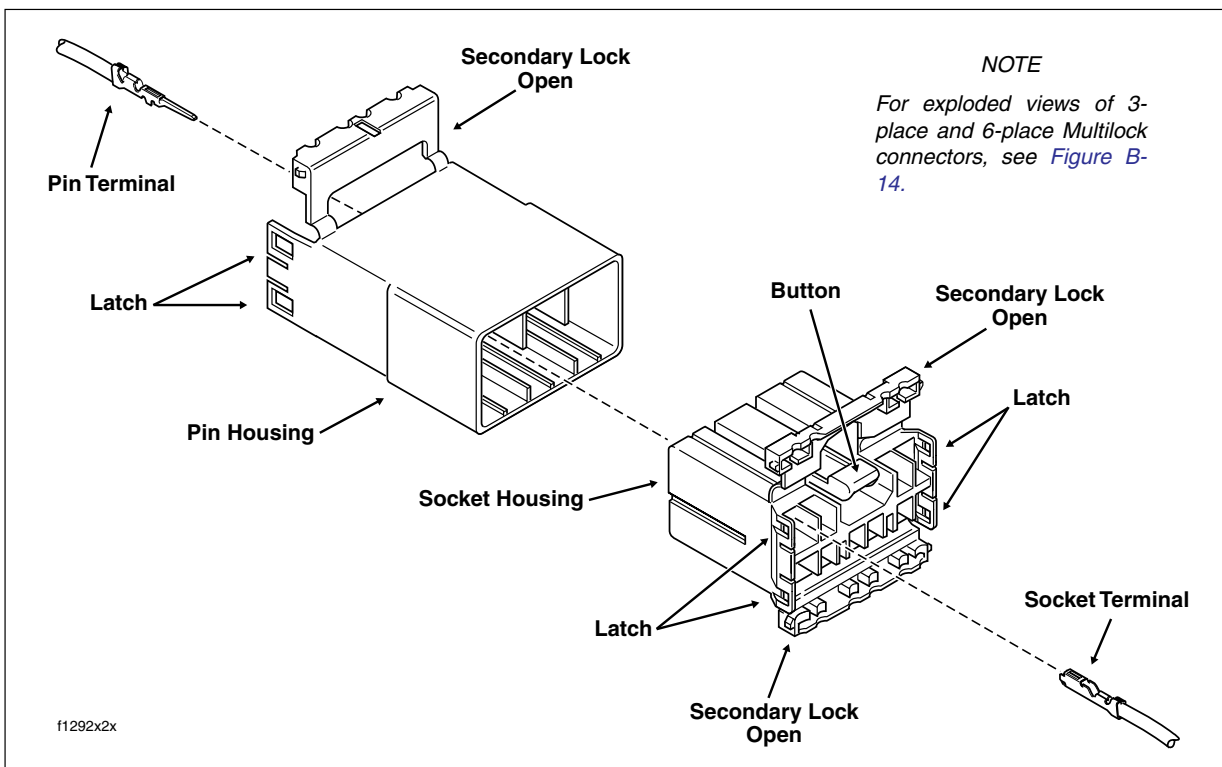

Figure B-10. 10-Place Multilock Connector (Exploded View)

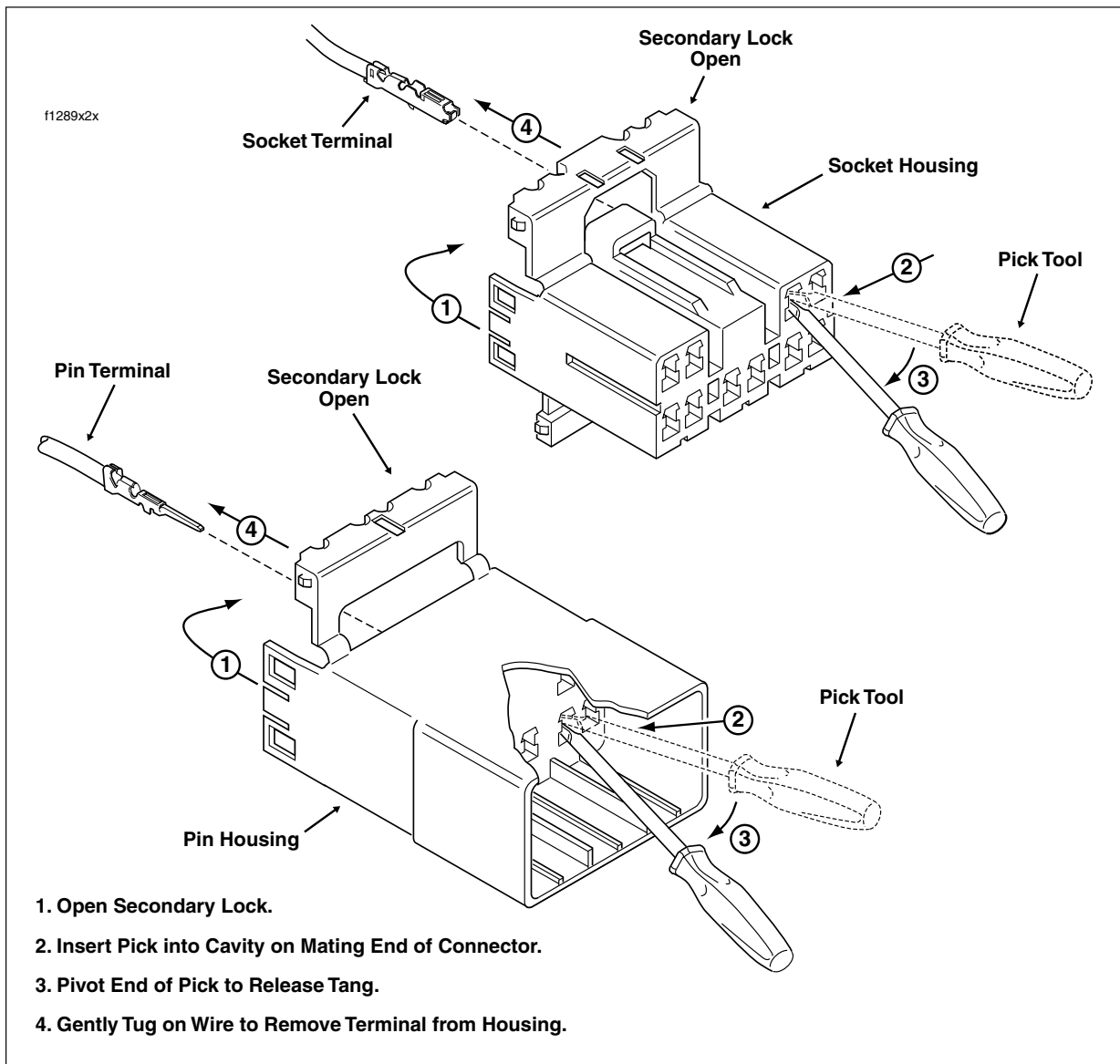

Figure B-11. Release Tang and Back Out Terminals

NOTE

The tang in the chamber engages the slot to lock the terminal in position. On the pin side of the connector, tangs are positioned at the bottom of each chamber, so the slot in the pin terminal (on the side opposite the crimp tails) must face downward. On the socket side, tangs are at the top of each chamber, so the socket terminal slot (on the same side as the crimp tails) must face upward. Up and down can be determined by the position of the release button (used to separate the pin and socket halves), the button always being the top of the connector. See [Figure B-12](#).

2. Gently tug on wire end to verify that the terminal is locked in place and will not back out of chamber.

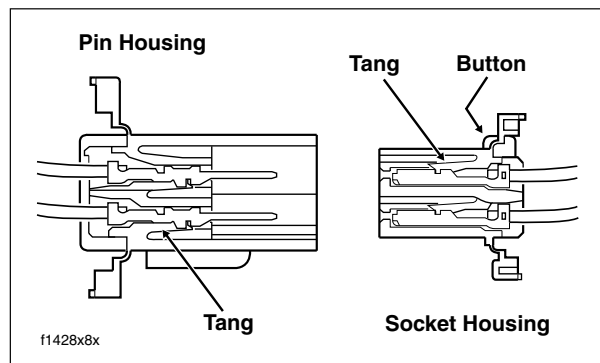
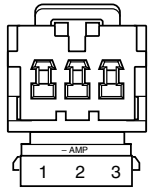

Figure B-12. Tang Location (Cross Sectional View)

f1287x2x

Secondary Locks Open



3-Place Connector

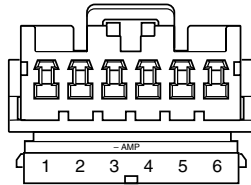

6-Place Connector

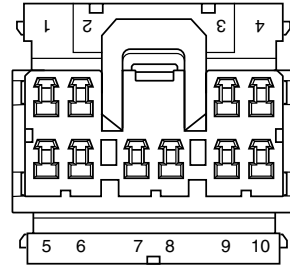

10-Place Connector

Figure B-13. Numbers Stamped on Secondary Locks for Wire Color Locations (Socket Housings Shown)

3-Place Connector

f1291x2x

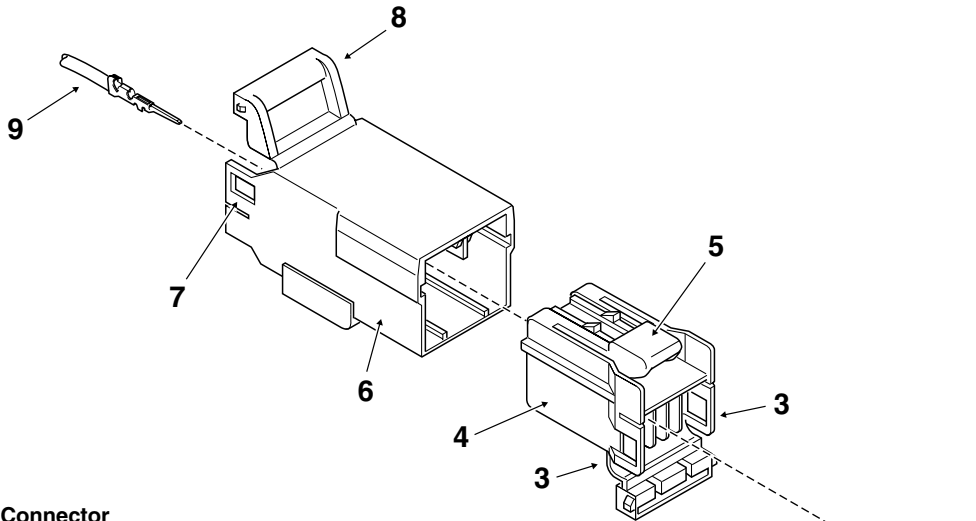

6-Place Connector

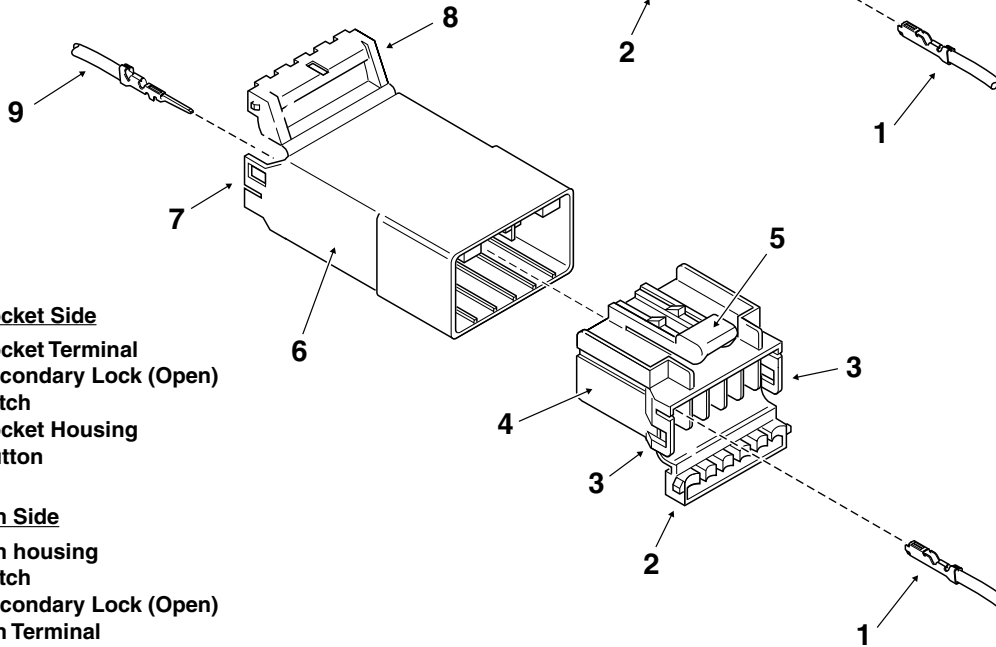

Socket Side

- 1. Socket Terminal
- 2. Secondary Lock (Open)
- 3. Latch
- 4. Socket Housing
- 5. Button

Pin Side

- 6. Pin housing
- 7. Latch
- 8. Secondary Lock (Open)
- 9. Pin Terminal

f1288x2x

Figure B-14. 3-Place and 6-Place Multilock Connectors

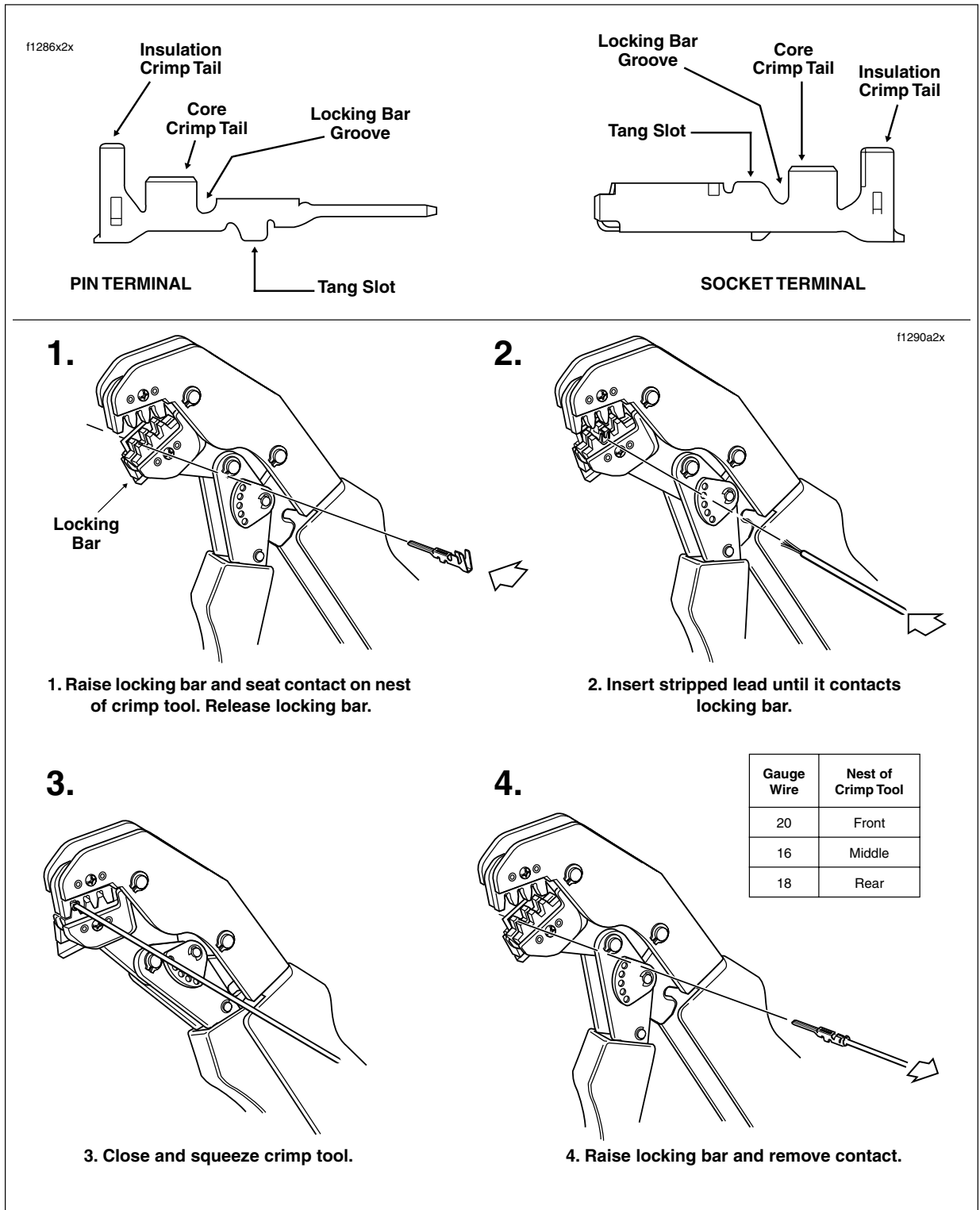

Figure B-15. Multilock Crimping Procedure

3. Rotate the hinged secondary lock inward until tabs fully engage latches on both sides of connector.
4. Insert the socket housing (plug) into the pin housing (receptacle) until it snaps in place.
5. Install connector on retaining device, either attachment or rosebud clip.

CRIMPING INSTRUCTIONS

1. Squeeze the handles to cycle the crimp tool (Part No. HD-41609) to the fully open position.
2. Raise locking bar by pushing up on bottom flange. With the crimp tails facing upward, insert contact (socket/pin) through locking bar, so that the closed side of the contact rests on the nest (concave split level area) of the crimp tool). Use the front nest for 20 gauge wire, the middle for 16 gauge and the rear for 18 gauge. See [Figure B-15](#).
3. Release locking bar to lock position of contact. When correctly positioned, the locking bar fits snugly in the space at the front of the core crimp tails.
4. Strip lead removing 5/32 inch (4.0 mm) of insulation. Insert wires between crimp tails until ends make contact with locking bar. Verify that wire is positioned so that short pair of crimp tails squeeze bare wire strands, while long pair folds over insulation material.
5. Squeeze handle of crimp tool until tightly closed. Tool automatically opens when the crimping sequence is complete. Raise up locking bar and remove contact.
6. Inspect the quality of the core and insulation crimps. Distortion should be minimal.

GENERAL

Use these instructions to service the following connectors:

- Ignition Coil [83B]
- Front Fuel Injector [84B]
- Rear Fuel Injector [85B]
- IAC [87B]
- TP Sensor [88B]
- IAT Sensor [89B]
- ET Sensor [90B]
- Oil Pressure Sender [139B]
- Security Siren [142B]

REMOVING SOCKET TERMINALS

NOTE

Although the parts of the different Delphi connectors vary in appearance, the instructions which follow will work for all. The only exception is the oil pressure sender connector [139B], the terminals of which are removed like the Packard push-to-seat connectors. Therefore, see Section B.4 [PACKARD ELECTRICAL CONNECTORS, 150 METRI-PACK SERIES](#), to remove/install terminals in this connector.

1. Bend back the external latch(es) slightly and separate pin and socket halves of connector.
2. If present, free one side of wire lock from ear on wire end of socket housing, then release the other side. Release wires from channels in wire lock and remove from socket housing. See [Figure B-16](#).
3. Use a fingernail to pry colored terminal lock loose and then remove from mating end of socket housing. See [Figure B-17](#).
4. Using a thin flat blade, like the unsharpened edge on an X-Acto knife, gently pry tang outward away from terminal, and then tug on wire to back terminal out wire end of chamber. Do not pull on wire until tang is released or terminal will be difficult to remove. See [Figure B-18](#).

INSTALLING SOCKET TERMINALS

NOTE

For wire location purposes, alpha or numeric characters are stamped into the wire end of each socket housing.

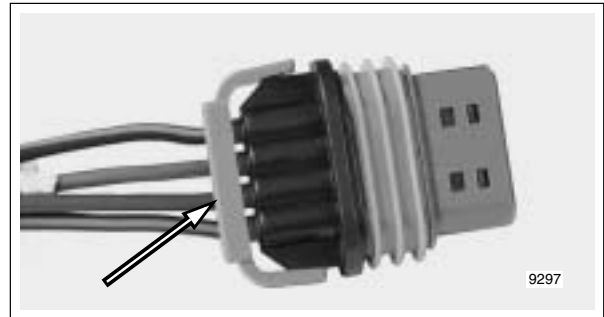

Figure B-16. Remove Wire Lock

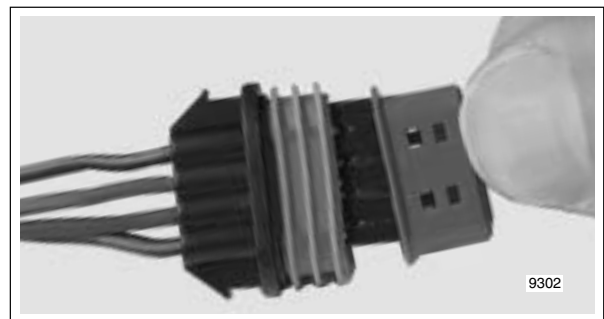

Figure B-17. Remove Terminal Lock

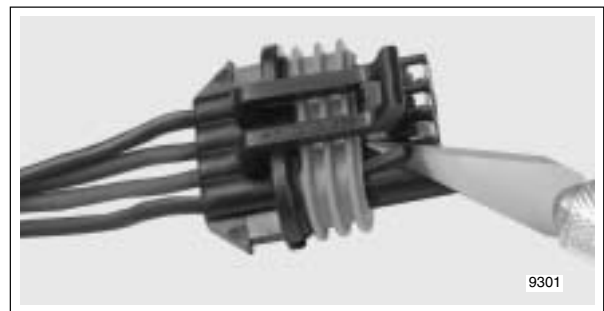

Figure B-18. Gently Pry Away Tang

1. Gently push tang on socket housing inward toward chamber. With the open side of the terminal facing the tang, push terminal into chamber at wire end of socket housing.
2. Gently tug on wire to verify that terminal is locked and will not back out of chamber. If necessary, use fingernail to push tang into engagement with terminal.
3. Install colored terminal lock onto mating end of socket housing. See [Figure B-17](#).

4. If present, seat wires in separate channels of wire lock and then push channels inside chambers at wire end of socket housing. Fully installed, slot on each side of wire lock engages ear on socket housing. See [Figure B-16](#).
5. Push pin and socket halves of connector together until external latch(es) engage.

150 METRI-PACK SERIES

General

Use these instructions to service the following connectors:

- Cruise Control Module [17B]
- MAP Sensor [80B]
- Fuel Level Sender/Fuel Pump [141B]

Disassembly

1. Bend back the external latch slightly and separate the pin and socket halves of the connector.
2. Note that there are two types of connectors in this series, pull-to-seat terminal and push-to-seat terminal connectors. Remove wire lock from wire end of socket housing on push-to-seat type connectors. For best results, free one side of wire lock first and then release the other side. See A of [Figure B-20](#).
3. Look into the mating end of the connector to find the locking tang. The tangs are always positioned in the middle of the chamber and are on the same side as the external latch.
4. Gently insert the point of a one inch safety pin into the chamber about 1/8 inch (3.2 mm) staying between the terminal and the chamber wall, and then pivot the end of the pin toward the terminal body. See B in [Figure B-19](#) or [Figure B-20](#). On push-to-seat type connectors, take note that there is a small opening for insertion of the pin.
5. If a click is heard, remove the pin and repeat the procedure. The click is the sound of the tang returning to the locked position as it slips from the point of the pin. Pick at the tang in this manner until the clicking stops and the pin seems to slide in at a slightly greater depth than it had previously. This is an indication that the tang has been depressed.

NOTE

On those terminals that have been extracted on multiple occasions, no clicking sound may be heard when the pin is pivoted to depress the tang, but proceed as if the clicking is audible.

6. Remove the pin. On pull-to-seat connectors, push on the lead to extract the terminal from the mating end of the connector. See C in [Figure B-19](#). On push-to-seat connectors, pull on the lead to draw the terminal out the wire end. See C in [Figure B-20](#).

7. If necessary, crimp new terminals on wires. See [Crimping Instructions](#) at the end of this section.

Assembly

NOTE

For wire location purposes, alpha characters are stamped into the socket housings.

1. Using a thin flat blade, like that on an X-Acto knife, carefully bend the tang outward away from the terminal body. See D in [Figure B-19](#) or [Figure B-20](#).
2. Gently pull or push on the lead to install the terminal back into the chamber. A click is heard when the terminal is properly seated.
3. Gently pull or push on the lead to verify that the terminal is locked in place.
4. On push-to-seat type connectors, seat wires in separate channels of wire lock and then push channels inside chambers at wire end of socket housing. Fully installed, slot on each side of wire lock engages ear on socket housing. See A of [Figure B-20](#).
5. Connect the pin and socket halves of the connector.

280 METRI-PACK SERIES

General

Use these instructions to service the following:

- System Fuse Block [64B]

System Fuse Block

Disassembly

1. Remove system fuses and relay(s) from fuse block. See [Section 8.3 SYSTEM FUSES, SYSTEM FUSES/RELAYS, REMOVAL](#).
2. Remove secondary locks as follows:
 - a. Insert end of small flat blade screwdriver under lip of locking wedge and gently pry up secondary lock.

NOTE

For best results, start with locking wedge on outboard side of secondary lock. See [Figure B-21](#).

3. Remove socket terminals as follows:
 - a. Looking into chamber at top of fuse block, note the tang next to each socket terminal.

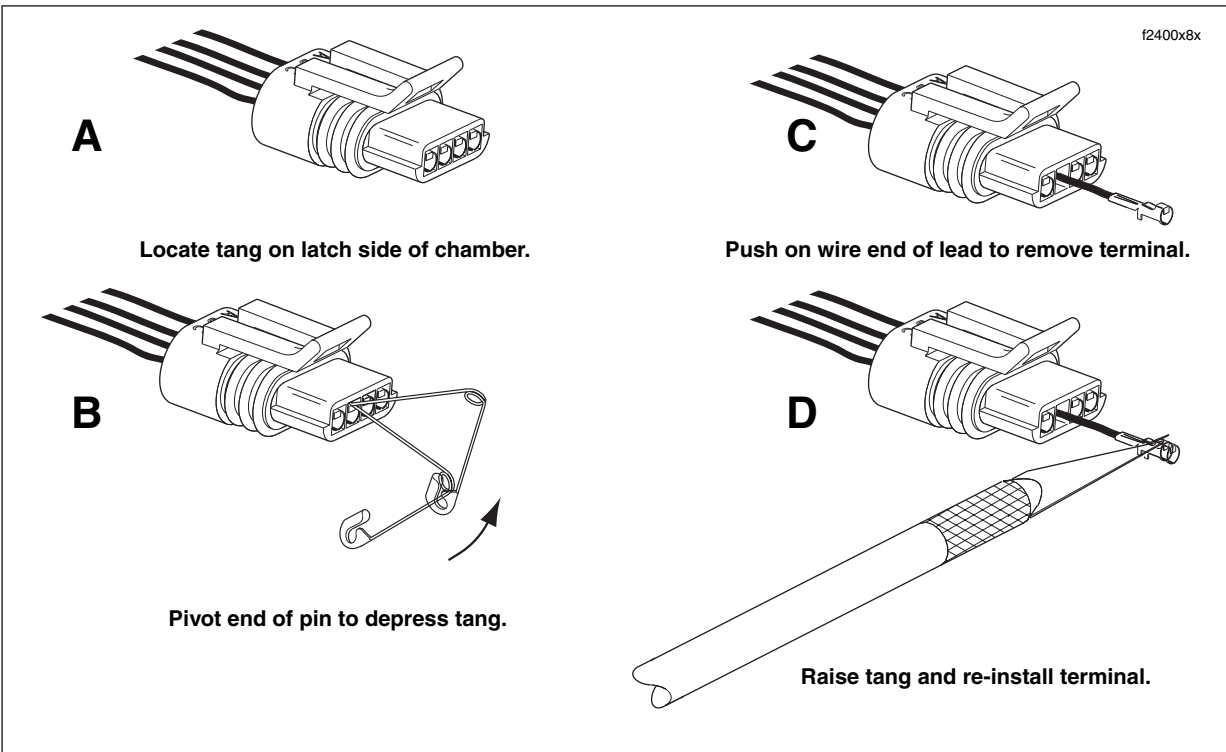

Figure B-19. Depress Tang and Extract Terminal From Mating End of Pull-to-Seat Connector

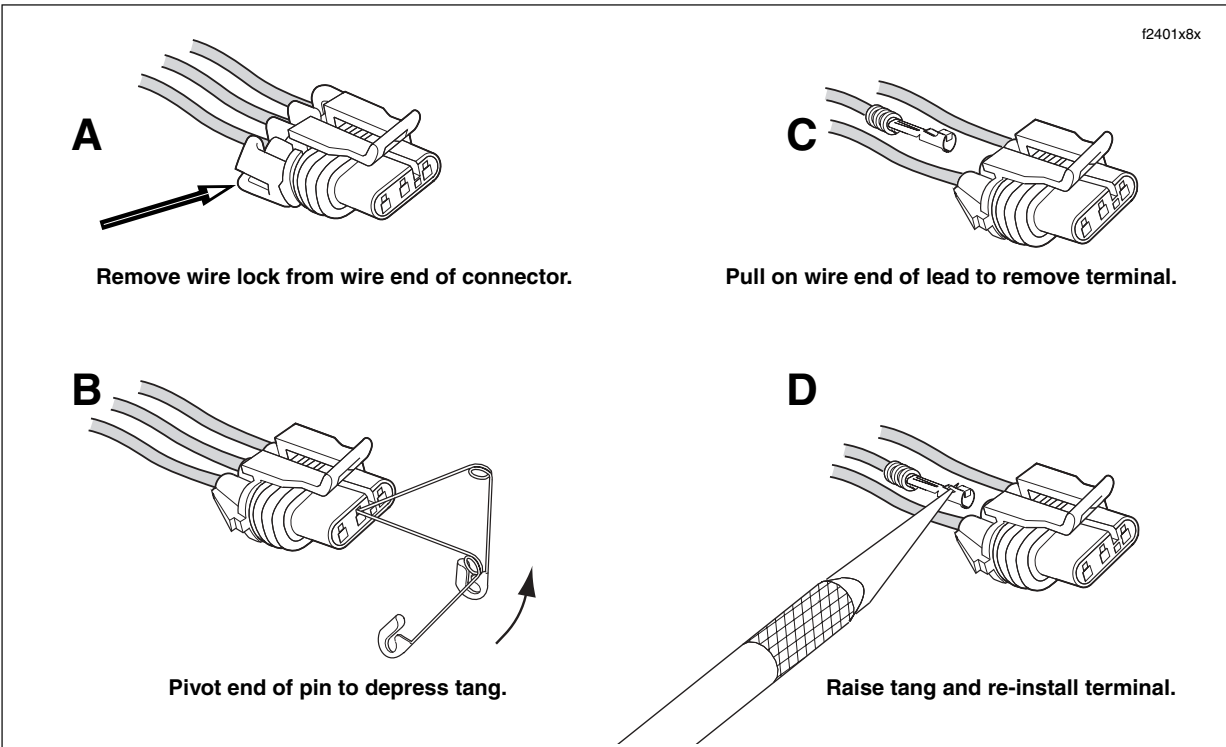

Figure B-20. Depress Tang and Extract Terminal From Wire End of Push-to-Seat Connector

- b. Using a thin flat blade, like that on an X-Acto knife, gently push tang away from terminal, and then tug on wire to back terminal out wire end of chamber.
4. If necessary, crimp new terminals on wires. See [Crimping Instructions](#) at the end of this section.

Assembly

1. Install socket terminals as follows:

NOTE

See Section [B.9 WIRING DIAGRAMS, MAIN HARNESS](#), for wire colors and locations.

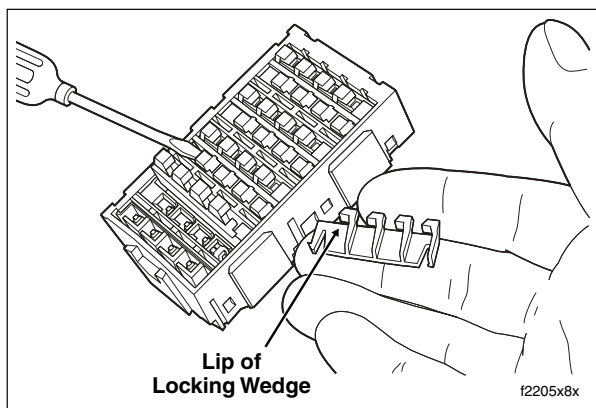

Figure B-21. Remove Secondary Locks From Fuse Block

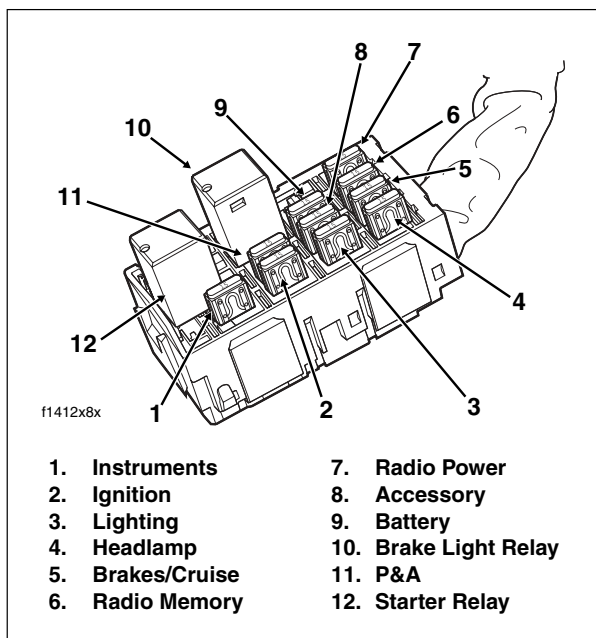

Figure B-22. Fuse Block (FLHX, FLHTC/U, FLTR)

- a. With the open side of the socket terminal facing the tang, push lead into chamber at the wire end of the fuse block. A click is heard when the terminal is properly engaged.
- b. Gently tug on the wire to verify that the terminal is locked in place and will not back out of the chamber.

2. Install secondary locks as follows:

- a. With the locking wedges positioned above the tangs in each chamber, slide flat side of secondary lock into slot (between rows), and push down until it bottoms. See [Figure B-21](#).

3. Install system fuses and relay(s) in fuse block. See Section [8.3 SYSTEM FUSES, SYSTEM FUSES/RELAYS, INSTALLATION](#).

480 METRI-PACK SERIES

General

Use these instructions to service the following connector:

- B+ [160]

Disassembly

1. Remove seat. See Section [2.25 SEAT, REMOVAL](#).

⚠ WARNING

Disconnect negative (-) battery cable first. If positive (+) cable should contact ground with negative (-) cable connected, the resulting sparks can cause a battery explosion, which could result in death or serious injury. (00049a)

2. Unthread bolt and remove battery negative cable (black) from battery negative (-) terminal.
3. Unthread bolt and remove battery positive cable (red) from battery positive (+) terminal.
4. Using a T40 TORX drive head, loosen bolt to move lip of hold-down clamp off edge of battery. Remove battery from battery box.
5. Cut anchored cable strap to release accessory connector and B+ connector from left side of frame crossmember (in front of battery box). See [Figure B-23](#).
6. Using small flat blade screwdriver, depress button on pin housing (red wire) side of the connector and pull apart the pin and socket halves. See A of [Figure B-24](#).

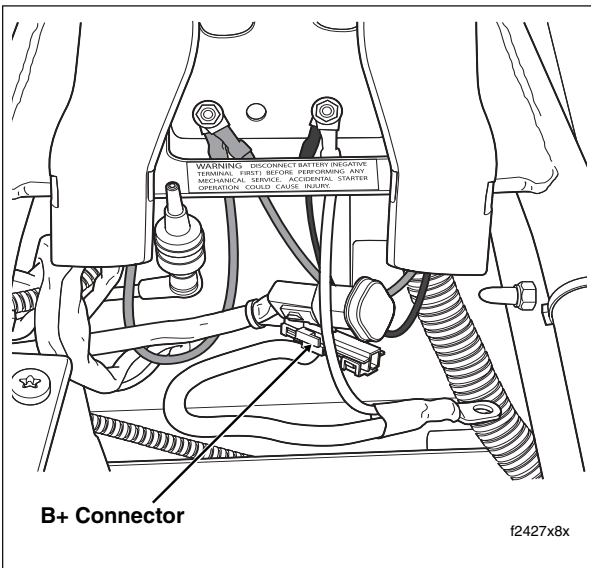

Figure B-23. Remove Seat

7. Bend back the latch slightly and free one side of secondary lock, then repeat the step to release the other side. Rotate the secondary lock outward on hinge to access terminal in chamber of connector housing. See B of Figure B-24.
8. On the mating end of the connector, note the tang in the square shaped opening centered next to the terminal. Gently insert the point of a stick pin or large safety pin into the opening between the tang and the chamber wall until it stops. Pivot the end of the pin toward the terminal body to depress the tang. Remove the pin and then pull terminal out wire end of connector housing. See C of Figure B-24.
9. If necessary, crimp new terminals on wires. See [Crimping Instructions](#) at the end of this section.

Assembly

1. Carefully bend the tang outward away from the terminal body.
2. With the tang on the same side as the square shaped opening in the mating end of the connector housing, feed terminal into wire end of connector housing until it “clicks” in place.
3. Verify that terminal will not back out of the chamber. A slight tug on the cable will confirm that it is locked.
4. Rotate the hinged secondary lock inward until latches fully engage tabs on both sides of connector housing.

5. Mate pin and socket halves of connector.
6. Install **new** anchored cable strap in lower hole on left side of frame crossmember (in front of battery box). Tighten cable strap to capture conduit of both accessory connector and B+ connector approximately one inch from connector housings. See [Figure B-23](#).
7. Place battery in battery box, terminal side forward.

⚠ WARNING

Connect positive (+) battery cable first. If positive (+) cable should contact ground with negative (-) cable connected, the resulting sparks can cause a battery explosion, which could result in death or serious injury. (00068a)

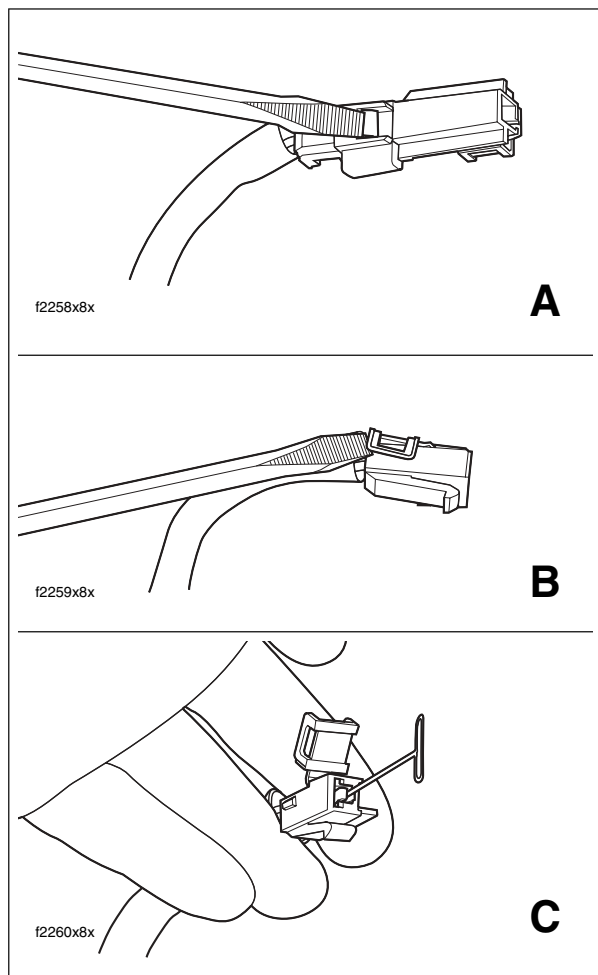

Figure B-24. Remove Socket Terminal

8. Insert bolt through battery positive cable (red) into threaded hole of battery positive (+) terminal. Tighten bolt to 60-96 **in-lbs** (6.8-10.9 Nm).
9. Insert bolt through battery negative cable (black) into threaded hole of battery negative (-) terminal. Tighten bolt to 60-96 **in-lbs** (6.8-10.9 Nm).
10. Rotate hold-down clamp so that the lip (with rubber pad) rests on the edge of the battery. Using a T40 TORX drive head, tighten the clamp bolt to 15-20 ft-lbs (20-27 Nm).
11. Install seat. See Section [2.25 SEAT, INSTALLATION](#).

630 METRI-PACK SERIES

General

Use these instructions to service the following connector:

- Main to Interconnect Harness [15]

Disassembly

1. Remove connector from barbed anchor or other retaining device, if present.
2. Bend back the external latch slightly and separate pin and socket halves of the connector.
3. Bend back the latch slightly and free one side of the secondary lock. Repeat the step to unlatch the other side.
4. Rotate the secondary lock outward on hinge to view the terminals in the chambers of the connector housing. The locking tang is on the side opposite the crimp tails and engages a rib in the chamber wall to lock the terminal in place.
5. Moving to the mating end of the connector, take note of the small opening on the chamber wall side of each terminal.
6. Insert pick (Snap-on® TT600-3) into opening until it stops. Pivot the end of the pick toward the terminal to depress the locking tang.
7. Remove the pick and gently tug on the wire to pull the terminal from the wire end of the connector. Repeat steps if the terminal is still locked in place.
8. If necessary, crimp new terminals on wires. See [Crimping Instructions](#) at the end of this section.

Assembly

NOTE

For wire location purposes, alpha characters are molded into the secondary locks of each connector housing.

1. Using a thin flat blade, like that on an X-Acto knife, carefully bend the tang outward away from the terminal body.
2. With the tang facing the chamber wall, push the lead into the chamber at the wire end of the connector. A click is heard when the terminal is properly seated.
3. Gently tug on the wire end to verify that the terminal is locked in place and will not back out of the chamber.
4. Rotate the hinged secondary lock inward until tabs fully engage latches on both sides of connector.
5. Push the pin and socket halves of the connector together until the latches “click.”
6. Install connector on barbed anchor or other retaining device, if present.

800 METRI-PACK SERIES

General

Use these instructions to service the following:

- Maxi-Fuse Holder [5]

Disassembly

1. Remove maxi-fuse. See Section [8.3 SYSTEM FUSES, MAXI-FUSE, REMOVAL](#).
2. Remove socket terminals as follows:
 - a. Gently pull socket housing to disengage slots from tabs on socket housing. See A of [Figure B-25](#). Free secondary lock from cables and set aside.
 - b. Take note of the opening on one side of the socket terminal. Gently insert flat blade of pick (Snap-On TT600-5) or small screwdriver into opening until it stops. Pivot the pick toward the terminal body and hold in position. See B of [Figure B-25](#).
 - c. Tug on cable to pull socket from wire end of socket housing. A firm tug is necessary to overcome the resistance of the rubber seal.
 - d. Repeat steps 2(b) and 2(c) to remove remaining socket terminal.
3. If necessary, crimp new terminals on wires. See [Crimping Instructions](#) at the end of this section.

Assembly

1. Install socket terminals as follows:
 - a. Carefully bend tang outward away from the terminal body. See C of [Figure B-25](#).

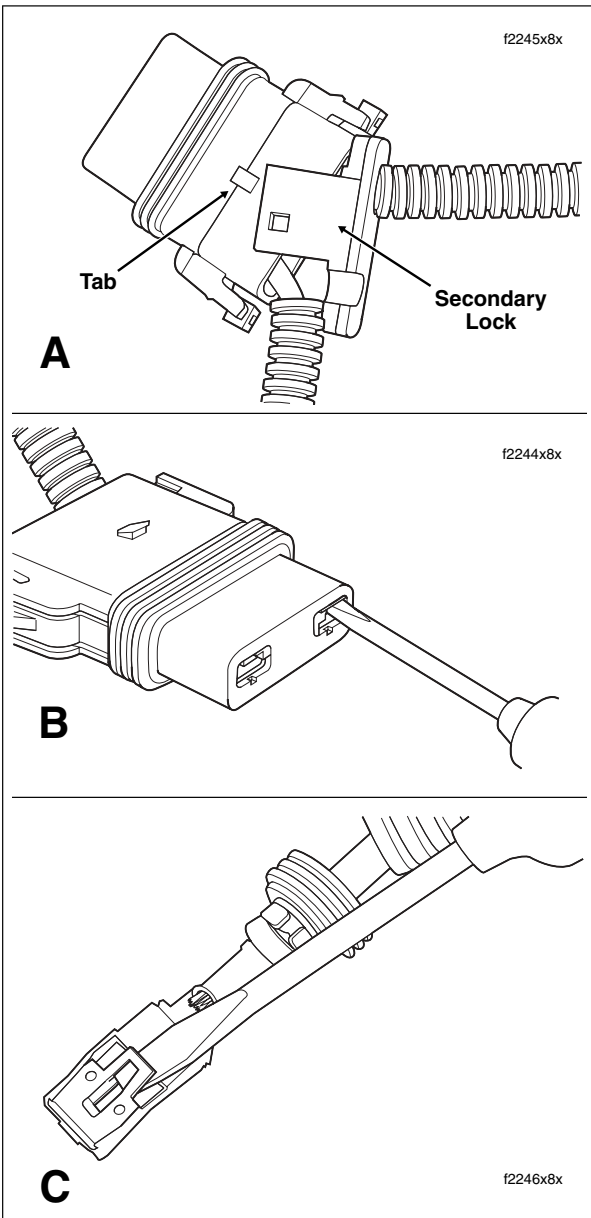

Figure B-25. Remove Socket Terminals

- b. Feed socket into wire end of socket housing until it "clicks" in place. Verify that socket will not back out of chamber. A slight tug on the cable will confirm that it is locked.
- c. Push rubber seal into wire end of socket housing.
- d. Repeat steps 1(a) thru 1(c) to install remaining socket terminal.

- e. Install secondary lock onto cables and then push onto wire end of socket housing until slots engage tabs on sides of socket housing.

2. Install maxi-fuse. See Section 8.3 **SYSTEM FUSES. MAXI-FUSE, INSTALLATION.**

PACKARD MICRO 64

General

Use these instructions to service the following connectors:

- Speedometer [39]
- Tachometer [108]

Disassembly

1. Bend back the external latches slightly and separate the pin and socket halves of the connector.

NOTE

To differentiate between the speedometer and tachometer connectors, note that the speedometer connector has a second length of conduit leading to the odometer reset switch.

2. Locate the head of the secondary lockpin on one side of the connector housing. See [Figure B-27](#).
3. Insert the blade of a small screwdriver between the center ear of the lockpin and the connector housing and gently pry out lockpin. When partially removed, pull lockpin from connector housing.
4. Obtain the Packard Micro 64 Terminal Remover (HD-45928). See [Figure B-26](#). Proceed as follows:
 - a. Locate small hole between terminals on mating end of connector. See [Figure B-27](#).

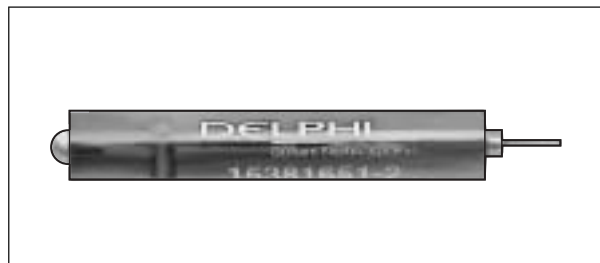

Figure B-26. Packard Micro 64 Terminal Remover (Part No. HD-45928).

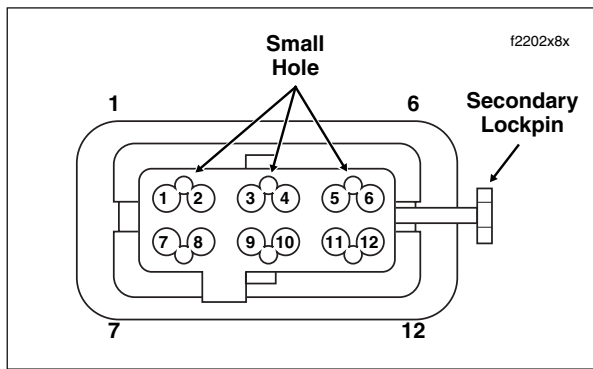

Figure B-27. Mating End of Connector

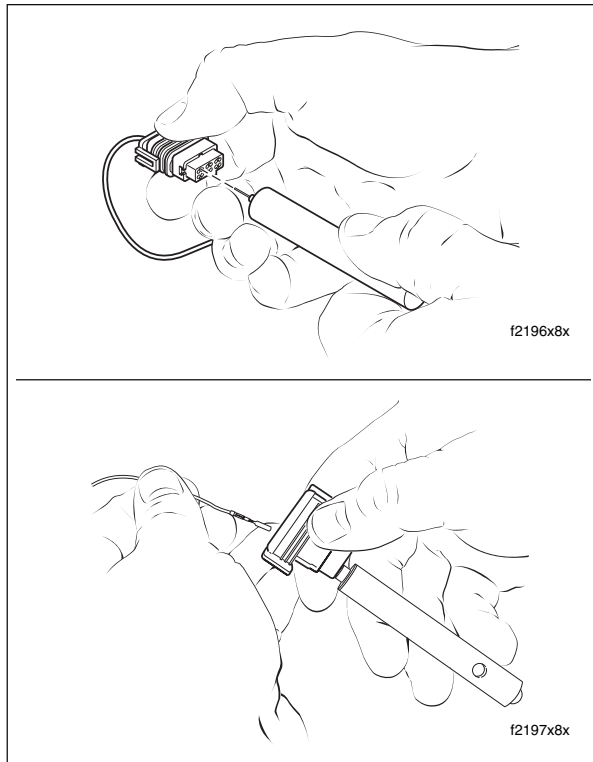

Figure B-28. Insert Tool and Remove Terminal

- b. Push the adjacent terminals all the way into the connector housing and then insert tool into hole until it bottoms. See upper frame of [Figure B-28](#).
 - c. Leaving the tool installed, gently tug on wires to pull either one or both terminals from wire end of connector. See lower frame of [Figure B-28](#). Remove tool.
5. If necessary, crimp new terminals on wires. See [Crimping Instructions](#) on this page.

Assembly

1. Insert terminal into its respective numbered chamber on wire end of connector. No special orientation of the terminal is necessary.

NOTE

For wire location purposes, the corners of the socket housing are stamped with the numbers 1, 6, 7 and 12, representing terminals 1-6 on one side, and 7-12 on the other. See [Figure B-27](#).

2. Bottom the terminal in the chamber and then gently tug on the wire to verify that it is locked in place.

NOTE

Once the terminal is removed it may not lock in place when first reinstalled. Until the lock engages, move the terminal back and forth slightly while wiggling the lead.

3. Since the terminal remover tool releases two terminals simultaneously, repeat step 2 on the adjacent terminal even if it was not pulled from the connector housing.
4. With the center ear on the head of the secondary lockpin facing the mating end of the connector, push lockpin in until head is flush with the connector housing.
5. Push the pin and socket halves of the connector together until the latches "click."

Crimping Instructions

1. Strip lead removing 1/8 inch (3.0 mm) of insulation.
2. Obtain the Packard Micro 64 Terminal Crimper (HD-45929). See [Figure B-29](#).
3. Squeeze the handles to cycle the tool to the fully open position.
4. Obtain **new** contact (socket terminal). Verify that contact and crimp tails are not bent or deformed.
5. Raise locking bar and barrel holder by pushing up on bottom tab with index finger. See [Figure B-30](#).

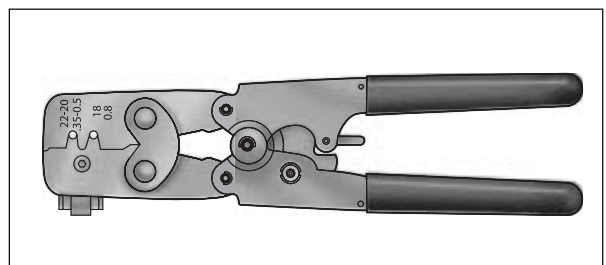

Figure B-29. Packard Micro 64 Terminal Crimper (Part No. HD-45929)

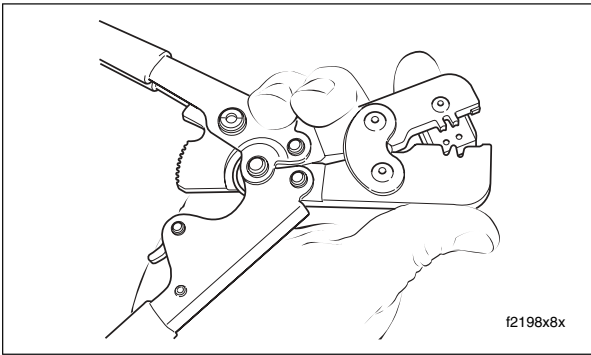

Figure B-30. Raise Locking Bar and Barrel Holder

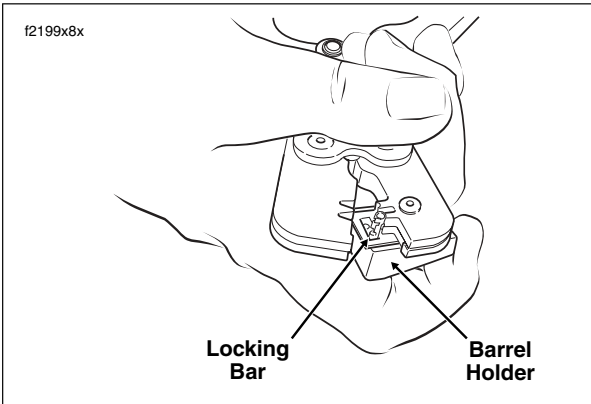

Figure B-31. Position Contact in Crimper

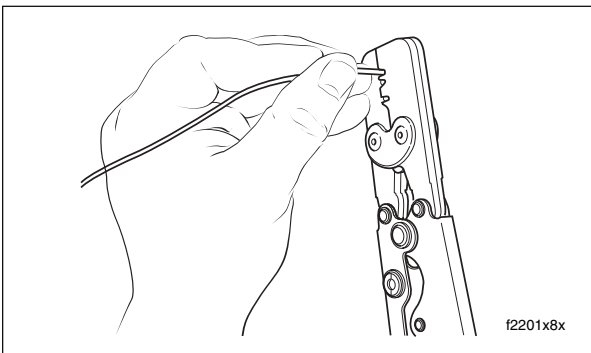

Figure B-32. Crimp Terminal Onto Wire

6. With the crimp tails facing upward, insert contact through locking bar into front hole in barrel holder (20-22 gauge wire).
7. Release locking bar to lock position of contact. When correctly positioned, the locking bar fits snugly in the space at the front of the core crimp tails and the closed side of the terminal rests on the outer nest of the crimp tool. See [Figure B-31](#).

8. Insert wires between crimp tails until ends make contact with locking bar. Verify that wire is positioned so that wide pair of crimp tails squeeze bare wire strands, while the narrow pair folds over the insulation material.
9. Squeeze handle of crimp tool until tightly closed. Tool automatically opens when the crimping sequence is complete. See [Figure B-32](#).
10. Raise locking bar and barrel holder to remove contact.
11. Inspect the quality of the core and insulation crimps. Distortion should be minimal.

PACKARD 100W

General

Use these instructions to service the following connector:

- ECM [78]

Disassembly

1. Gently depress latch on each side of the clear plastic secondary lock and remove. For best results, release one side at a time, See [Figure B-33](#).

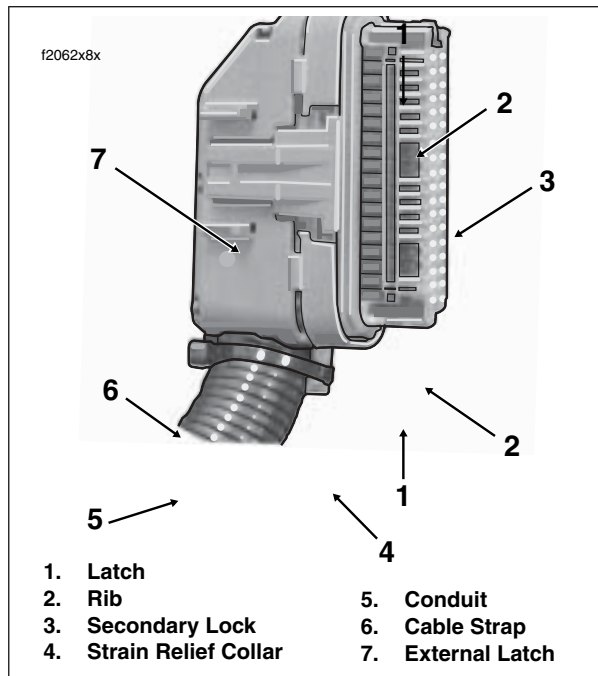

- | | |
|-------------------------|-------------------|
| 1. Latch | 5. Conduit |
| 2. Rib | 6. Cable Strap |
| 3. Secondary Lock | 7. External Latch |
| 4. Strain Relief Collar | |

Figure B-33. Remove Secondary Lock

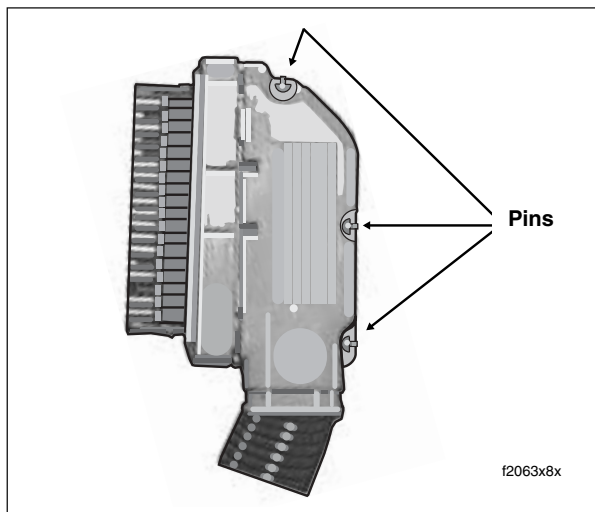

Figure B-34. Separate Halves of Socket Housing

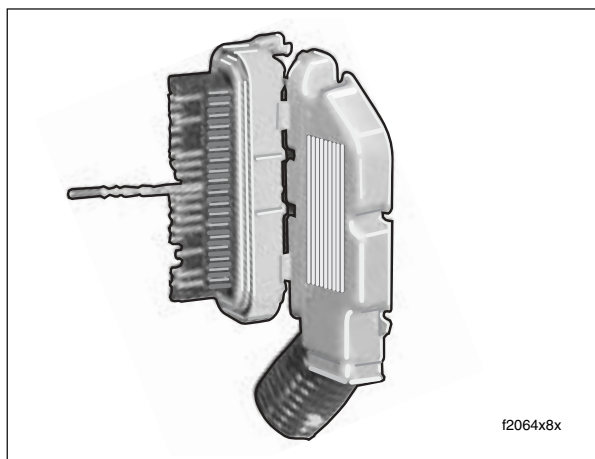

Figure B-35. Push Wire to Extract Terminal

- Carefully cut cable strap to free strain relief collar from conduit.
- Using a thin blade, gently pry at seam at back of socket housing to release three plastic pins from slots in housing. Separate and spread halves of socket housing. See [Figure B-34](#).
- Push on selected wire to free terminal from chamber. See [Figure B-35](#).
- If necessary, crimp new terminals on wires. See [Crimping Instructions](#) on this page.

Assembly

- From inside socket housing, gently pull on wire to draw terminal into chamber. See [Figure B-35](#).

- Exercising caution to avoid pinching wires, press halves of socket housing together until three plastic pins fully engage slots in housing. See [Figure B-34](#).
- Install **new** cable strap in groove of strain relief collar capturing cable conduit. See [Figure B-33](#).
- With the two ribs on the secondary lock on the same side as the external latch, install over terminals until latches lock in place.

Crimping Instructions

- Strip wire lead removing 5/32 inch (4.0 mm) of insulation.
- Compress handles until ratchet automatically opens.

NOTE

Always perform core crimp before insulation/seal crimp.

- See [Figure B-36](#). Determine the correct die or nest for the core crimp.
- Position the core crimp on the appropriate nest. Be sure the core crimp tails are facing the forming jaws.

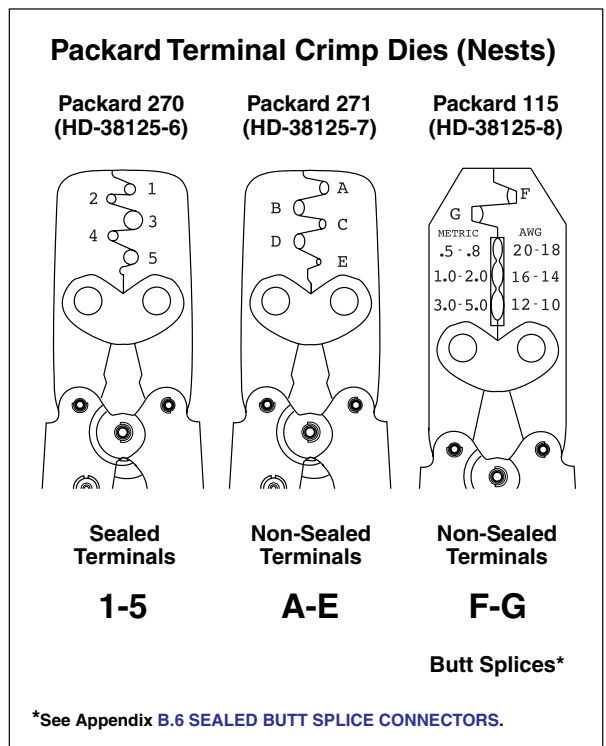

Figure B-36. Packard Terminal Crimp Tools

5. Gently apply pressure to handles of tool until crimpers just secure the core crimp tails.
6. Insert stripped wire between crimp tails. Verify that wire is positioned so that short pair of crimp tails squeeze bare wire strands, while long pair is positioned over the insulation or seal material.
7. Squeeze handle of crimp tool until tightly closed. Tool automatically opens when the crimping sequence is complete.
8. See [Figure B-36](#). Determine the correct die or nest for the insulation/seal crimp.
9. Position the insulation/seal crimp on the appropriate nest. Be sure the insulation/seal crimp tails are facing the forming jaws.
10. Squeeze handle of crimp tool until tightly closed. Tool automatically opens when the crimping sequence is complete.
11. Inspect the quality of the core and insulation/seal crimps. Distortion should be minimal. See [Figure B-37](#).

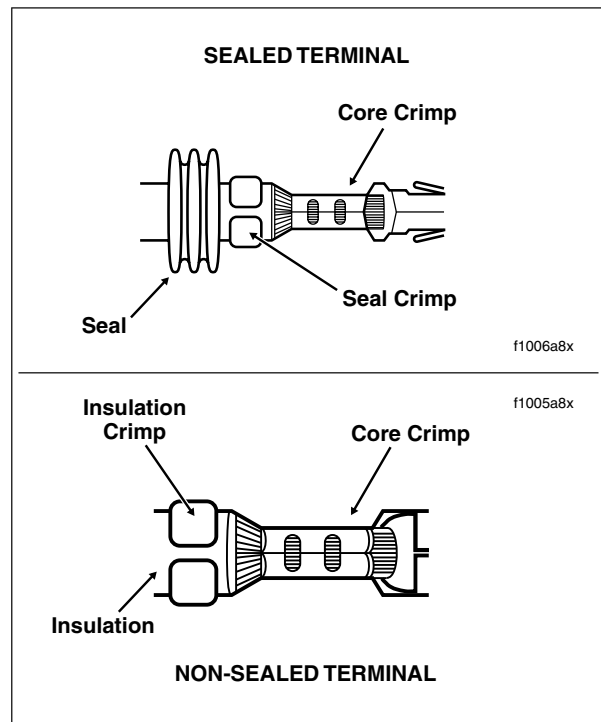

Figure B-37. Inspect Core and Insulation/Seal Crimps

GENERAL

Use these instructions to service the following connector:

- Ignition Light/Key Switch [33B]

DISASSEMBLY

1. Obtain terminal pick (Snap-on® GA500A) like that shown [Figure B-38](#).
2. Insert smallest pair of pins into chamber on mating end of socket housing to depress tangs on each side of terminal simultaneously.
3. Gently pull on wire to remove terminal from wire end of socket housing.
4. If necessary, crimp new terminals on wires.

ASSEMBLY

1. Using a thin flat blade, like that on an X-Acto knife, carefully bend tang on each side of terminal outward away from terminal body.
2. With the open side of the terminal facing rib on wire end of socket housing, insert terminal into chamber until it locks in place.

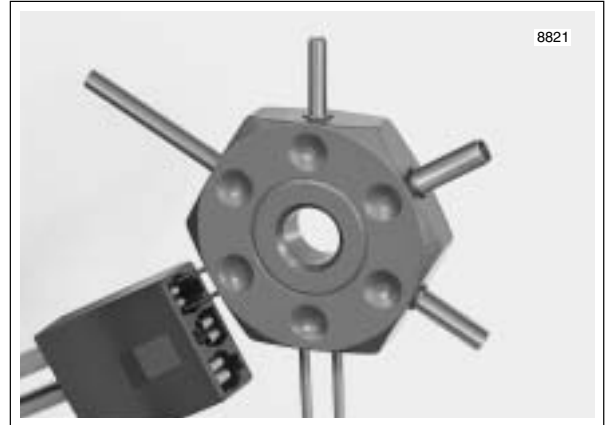

Figure B-38. Depress Tangs and Remove Terminal

PROCEDURE

Butt splicing may be a necessary procedure for the replacement of some components. Proceed as follows:

- Strip 3/8 inch (9.5 mm) of insulation off the ends of the wires.
- Compress the handles of the Packard Crimp Tool (HD-38125-8) until the ratchet automatically opens.
- Since the size of the connectors vary with the gauge of the wire, reference the following table to ensure properly sealed splices are used.

Gauge Wire	Connector Color	Part Number
18-20	Red	P/N 70585-93
14-16	Blue	P/N 70586-93
10-12	Yellow	P/N 70587-93

- Determine the correct die or nest for the crimping operation. Match the color or gauge wire marked on the butt splice connector with the corresponding crimp cavity on the crimp tool. See Figure B-39.
- Gently apply pressure to the handles until the crimper lightly secures one side of the metal insert inside the butt splice connector. The connector must be crimped in two stages, one side and then the other.
- See Figure B-40. Feed the wire into the butt splice connector until the stripped end contacts the wire stop inside the metal insert.
- Squeeze the handles of the crimp tool until tightly closed. The tool automatically opens when the crimping sequence is complete.

- Repeat steps 5-7 on the other side of the butt splice connector.

NOTE

If adjacent wires are being spliced, stagger the splices so that the butt splice connectors are spaced at different positions along the length of the wires.

- Using the UltraTorch UT-100 (HD-39969), Robinair Heat Gun (HD-2507 41183) or other suitable radiant heating device, heat the crimped splice to encapsulate the butt splice connection. Apply heat from the center of the crimp out to each end until the meltable sealant exudes out both ends of the connector. See Figure B-40.

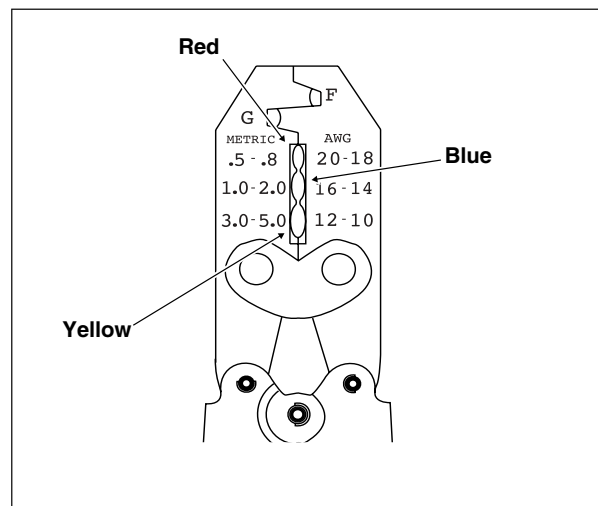

Figure B-39. Packard Crimp Tool (HD-38125-8)

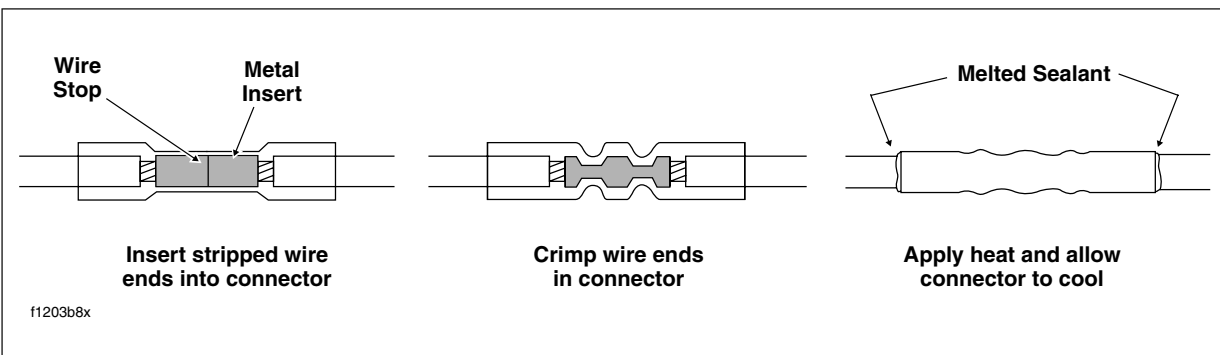

Figure B-40. Installing Sealed Butt Splice Connectors

⚠ WARNING

Be sure to follow manufacturer's instructions when using the UltraTorch UT-100 or any other radiant heating device. Failure to follow manufacturer's instructions can cause a fire, which could result in death or serious injury. (00335a)

- Avoid directing heat toward any fuel system component. Extreme heat can cause fuel ignition/explosion resulting in death or serious injury.
- Avoid directing heat toward any electrical system component other than the connectors on which heat shrink work is being performed.
- Always keep hands away from tool tip area and heat shrink attachment.

NOTE

It is acceptable for the splice to rest against the heat shrink tool attachment.

10. Heat the center of the splice until the crimp indentations disappear and the tubing assumes a smooth cylindrical appearance.

REMOVING TERMINALS

1. Remove maxi-fuse. See Section 8.3 SYSTEM FUSES. MAXI-FUSE, REMOVAL.
2. Depress external latch and disconnect pin and socket halves of connector.

CAUTION

Exercise care to avoid completely removing secondary lock, particularly on the socket housing side. Removal will allow the terminals to rotate inside the chambers, which prevents reinstallation of the secondary lock. If this does occur, remove all terminals from the connector housing before reinstalling the secondary lock.

3. Pull up the secondary lock on the mating end of the connector about 3/16 inch (4.8 mm).

NOTE

Using center holes, grasp secondary lock in pin housing with a small needle nose pliers. See Figure B-42. On the socket housing, engage slot on outer edge and gently pry up secondary lock with a small flat blade screwdriver. The slot next to the external latch provides the best pivot point. See Figure B-43.

4. Obtain the MOLEX ELECTRICAL CONNECTOR TERMINAL REMOVER (HD-48114) and proceed as follows:
 - a. Insert pin of tool into small round hole in secondary lock adjacent to selected terminal until it bottoms. See Figure B-44.
 - b. Gently pull wire to extract terminal from chamber of pin or socket housing.
 - c. Remove tool from secondary lock.

INSTALLING TERMINALS

NOTE

The wire end of both the pin and socket housings are stamped to indicate terminal locations. For example, one side of the 8-place connector is stamped 1 thru 4, while the other side is stamped 5 thru 8. The 16-place connector is stamped 1-8 and 9-16. See Figure B-45.

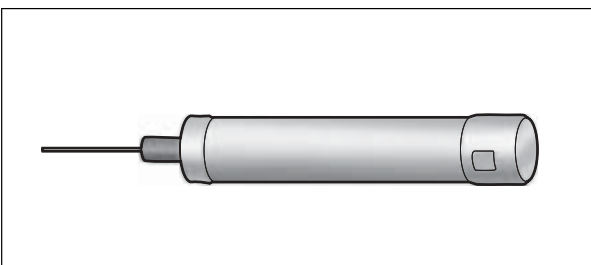

Figure B-41. Molex Connector Terminal Remover (Part No. HD-48114)

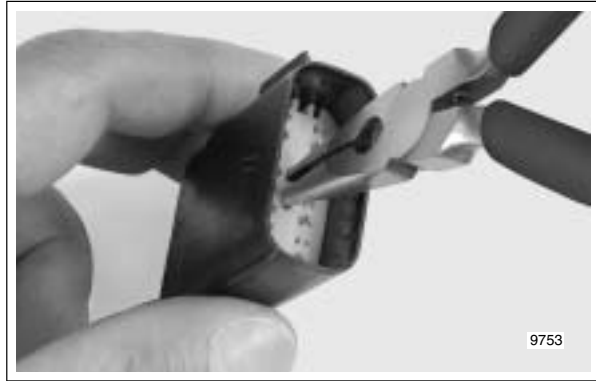

Figure B-42. Pull Up Secondary Lock (Pin Housing)



Figure B-43. Pry Up Secondary Lock (Socket Housing)

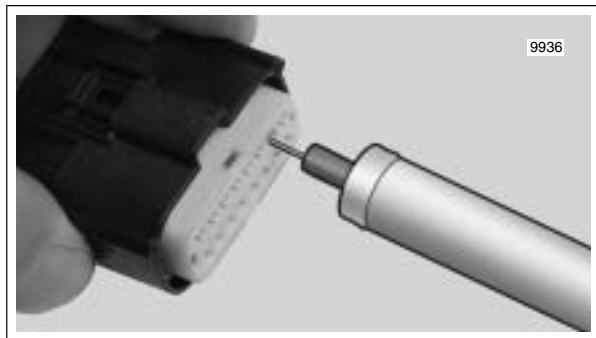

Figure B-44. Insert Molex Connector Terminal Remover (Part No. HD-48114)

1. Insert terminal into opening in wire end of connector. Note that locating tang on terminal (opposite crimp tails) engages slot in opening to prevent improper assembly.
2. Gently tug on wire to verify that the terminal is locked in place and will not back out of chamber.
3. Push secondary lock down into pin or socket housing about 3/16 inch (4.8 mm) until it bottoms.

[HOME](#)

4. Connect pin and socket halves of connector.
5. Install maxi-fuse. See Section [8.3 SYSTEM FUSES. MAXI-FUSE, INSTALLATION.](#)

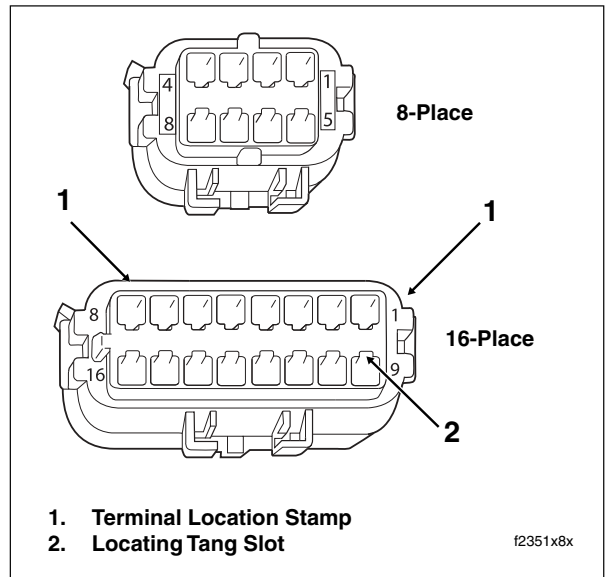

Figure B-45. Wire End (Pin Housing Shown)

FLHX, FLHT/C/U

No.	Description	Type	Location	Fig.
[1]	Main to Interconnect Harness	16 - Place Molex (Black)	Inner Fairing - Right Radio Support Bracket	46
[2]	Main to Interconnect Harness	12 - Place Molex (Gray)	Inner Fairing - Right Fairing Support Brace	46
[4]	Accessory	4 - Place Deutsch	Upper Frame Crossmember (Under Seat)	50
[5]	Maxi-Fuse	2 - Place Packard	Under Left Side Cover	47
[6]	Audio to Interconnect Harness	6 - Place Deutsch (Black)	Inner Fairing - Left Side of Radio	46
[7]	Rear Fender Lights Harness	8 - Place Multilock	Top of Rear Fender (Under Seat)	55
[12]	Tour-Pak Lights (Rear Facia Lamp on FLHX)	3 - Place Multilock	Inside Tour-Pak (Inboard of Upper Frame Tube on FLHX)	51
[13]	Fuel Tank Harness	4 - Place Multilock	Behind Fuel Tank (Under Seat)	50
[15]	Main to Interconnect Harness	4 - Place Packard	Inner Fairing - Right Fairing Bracket	46
[17]	Cruise Control Module **	10 - Place Packard	Under Left Side Cover	47
[18]	Left Rear Turn Signal	2 - Place Multilock	Circuit Board Under Tail Lamp Assembly	53
[19]	Right Rear Turn Signal	2 - Place Multilock	Circuit Board Under Tail Lamp Assembly	53
[21]	Indicator Lights	10 - Place Multilock	Inner Fairing - Above Radio	46
[22]	Interconnect to Right Handlebar Switches	12 - Place Molex (Black)	Inner Fairing - Fork Stem Nut Lock Plate (Left Side)	46
[24]	Interconnect to Left Handlebar Switches	16 - Place Molex (Gray)	Inner Fairing - Left Fairing Support Brace	46
[27]	Radio *	23 - Place Amp	Inner Fairing - Back of Radio (Right Side)	46
[28]	Radio **	35 - Place Amp	Inner Fairing - Back of Radio (Left Side)	46
[30]	TSM/HFSM	12 - Place Deutsch	Crossmember at Rear of Battery Box (Under Seat)	55
[31L]	Left Front Turn Signal/Auxiliary Lamp	4 - Place Multilock	Inner Fairing - Left Fairing Support Brace (Outboard Side)	46
[31R]	Right Front Turn Signal/Auxiliary Lamp	4 - Place Multilock	Inner Fairing - Right Fairing Support Brace (Outboard Side)	46
[32]	Front Fender Tip Lamp Jumper Harness (DOM)	2 - Place Multilock (Black)	Inner Fairing - Below Upper Fork Bracket (Left Side)	46
[33]	Ignition/Light Key Switch	3 - Place Packard	Inner Fairing - Under Radio (Front of Ignition Switch Housing)	46
[34]	Right Front Speaker	Spade Contacts	Inner Fairing (Back of Speaker)	-
[35]	Left Front Speaker	Spade Contacts	Inner Fairing (Back of Speaker)	-
[38]	Headlamp	Headlamp Connector	Inner Fairing (Back of Headlamp)	46
[39]	Speedometer	12 - Place Packard (Black)	Inner Fairing (Back of Speedometer)	46
[41]	Rear Right Speaker/Passenger Controls **	6 - Place Deutsch	Inside Rear Right Speaker Box	-
[42]	Rear Left Speaker/Passenger Controls **	6 - Place Deutsch	Inside Rear Left Speaker Box	-
[45]	Rear Fender Tip Lamp (DOM)	3 - Place Multilock	Circuit Board Under Tail Lamp Assembly	53
[46]	Stator	3 - Place Lyall	Bottom of Voltage Regulator (Left Side)	54
[50]	CB Antenna Cable **	-	Inner Fairing - Back of CB Module	46,51
[51]	Radio Antenna Cable *	-	Inner Fairing - Back of Radio (Left Side)	46
[53]	Console Pod **	12 - Place Deutsch	Rear of Battery Box (Under Seat)	52
[64]	Fuse Block	Packard	Under Left Side Cover	47,48
[65]	VSS	3 - Place Delphi	Top of Transmission Case (Under Starter)	-
[75]	Cruise Roll-Off Switch	Spade Contacts	Right Side of Steering Head	-
[76]	Passenger Headset	7 - Place DIN	Below Rear Left Speaker Box	-
[77]	Voltage Regulator	2 - Place Lyall	Bottom of Voltage Regulator (Right Side)	54
[78]	ECM	36 - Place Packard	Under Right Side Cover	49
[79]	CKP Sensor	2 - Place Deutsch	Electrical Caddy at Bottom of Lower Frame Crossmember	54
[80]	MAP Sensor	3 - Place Packard	Top of Induction Module	-
[83]	Ignition Coil	4 - Place Delphi	Below Fuel Tank (Left Side)	-
[84]	Front Injector	2 - Place Delphi	Below Fuel Tank (Left Side)	-
[85]	Rear Injector	2 - Place Delphi	Below Fuel Tank (Left Side)	-
[87]	IAC	4 - Place Delphi	Below Fuel Tank (Right Side)	-
[88]	TP Sensor	3 - Place Delphi	Below Fuel Tank (Right Side)	-
[89]	IAT Sensor	2 - Place Delphi	Below Fuel Tank (Right Side)	-

FLHX, FLHT/C/U Continued ...

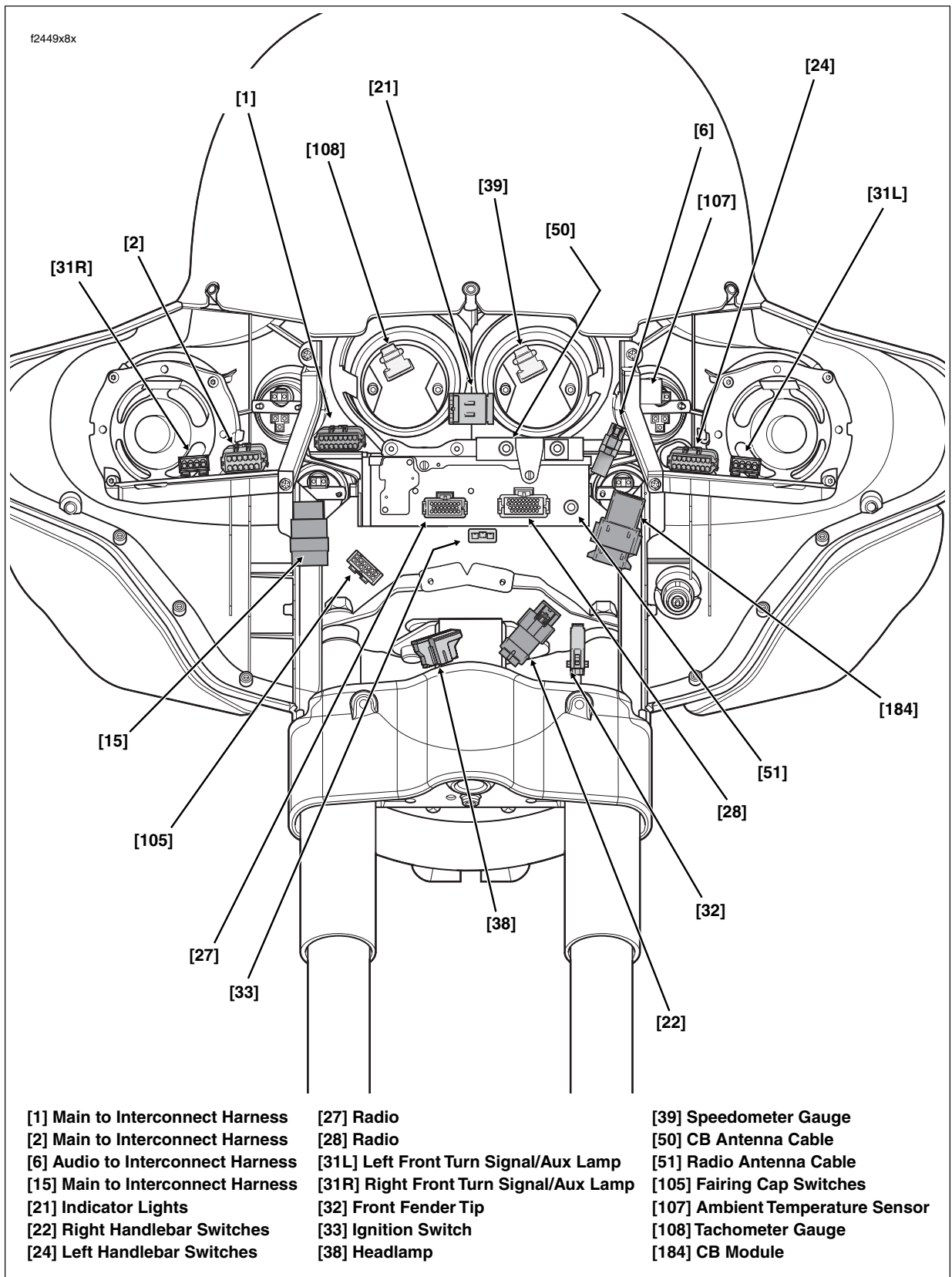

Figure B-46. Inner Fairing Connectors (FLHX, FLHT/C/U)

FLHX, FLHT/C/U (Continued)

No.	Description	Type	Location	Fig.
[90]	ET Sensor	2 - Place Delphi	Back of Front Cylinder (Left Side)	-
[91]	Data Link	4 - Place Deutsch	Under Right Side Cover	49
[93]	Tail Lamp	4 - Place Multilock	Circuit Board Under Tail Lamp Assembly	53
[94]	Rear Fender Lights Harness to Circuit Board	6 - Place Multilock	Circuit Board Under Tail Lamp Assembly	53
[105]	Fairing Cap Switches	12 - Place Multilock	Inner Fairing - Above Upper Fork Bracket (Right Side)	46
[107]	Ambient Air Temperature Sensor *	3 - Place Multilock	Inner Fairing - Left Fairing Bracket (Outboard Side)	46
[108]	Tachometer	12 - Place Packard (Gray)	Inner Fairing (Back of Tachometer)	46
[110]	Voltmeter Lamp	Spade Connector	Inner Fairing (Back of Voltmeter)	-
[111]	Voltmeter	Spade Connector	Inner Fairing (Back of Voltmeter)	-
[112]	Oil Pressure Gauge Lamp	Spade Connector	Inner Fairing (Back of Oil Pressure Gauge)	-
[113]	Oil Pressure Gauge	Spade Connector	Inner Fairing (Back of Oil Pressure Gauge)	-
[114]	Air Temperature Gauge Lamp	Spade Connector	Inner Fairing (Back of Air Temperature Gauge)	-
[115]	Air Temperature Gauge	Spade Connector	Inner Fairing (Back of Air Temperature Gauge)	-
[116]	Fuel Gauge Lamp	Spade Connector	Inner Fairing (Back of Fuel Gauge)	-
[117]	Fuel Gauge	Spade Connector	Inner Fairing (Back of Fuel Gauge)	-
[119]	EFI Fuses	Fuse Terminals	Fuse Block (Under Right Side Cover)	49
[121]	Rear Brake Light Switch	Spade Terminals	Bottom of Rear Frame Downtube (Right Side)	-
[122]	Horn	Spade Terminals	Between Cylinders (Left Side)	-
[123]	Starter Relay	Relay Connector	Fuse Block (Under Left Side Cover)	48
[124]	Brake Light Relay	Relay Connector	Fuse Block (Under Left Side Cover)	48
[126]	Ignition Keyswitch Relay	Relay Connector	Crossmember at Rear of Battery Box (Under Seat)	52
[128]	Starter Solenoid	Spade Terminals	Top of Starter	-
[129]	Harness Grounds	Ring Terminals	Upper Frame Crossmember (Under Seat)	50
[131]	Neutral Switch	Post Terminals	Top of Transmission (Right Side)	-
[132]	Cigarette Lighter *	Spade Terminals	Inner Fairing	-
[135]	EFI System Relay	Relay Connector	Fuse Block (Under Right Side Cover)	49
[137]	O ₂ Sensor Rear Exhaust Header	2 - Place Amp (Tyco)	Under Chrome Starter Cover	-
[138]	O ₂ Sensor Front Exhaust Header	2 - Place Amp (Tyco)	Back of Cross Brace Between Front Frame Downtubes (Left Side)	-
[139]	Oil Pressure Sender	4 - Place Delphi	Front Right Crankcase	-
[141]	Fuel Pump and Fuel Level Sender	4 - Place Packard	Top of Canopy (Under Console)	-
[142]	Security Siren (Optional)	3 - Place Delphi	Under Right Side Cover (Behind Electrical Bracket)	49
[143]	Front Fender Tip Lamp (DOM)	2 - Place Multilock (Black)	Under Front Fender Tip Lamp Bracket	-
[160]	B+	1 - Place Packard	Upper Frame Crossmember (Under Seat)	50
[178]	Active Intake Solenoid	2 - Place Amp (Tyco)	Back of Air Cleaner Backplate	-
[179]	Active Exhaust Actuator	5 - Place Amp (Tyco)	Domestic (Not Used): Under Right Side Cover	49
			HDI: Under Right Side Cover (Behind Electrical Bracket)	-
[184]	CB Module	12 - Place Deutsch	Inner Fairing - Left Side of Radio	46
[208]	HFSM Antenna Jumper Harness	4 - Place Deutsch	TSM/HFSM in Crossmember at Rear of Battery Box (Under Seat)	55
[209]	HFSM Antenna	2 - Place Molex	Top of Rear Fender (Under Seat)	55

* Classic and Ultra ** Ultra Only

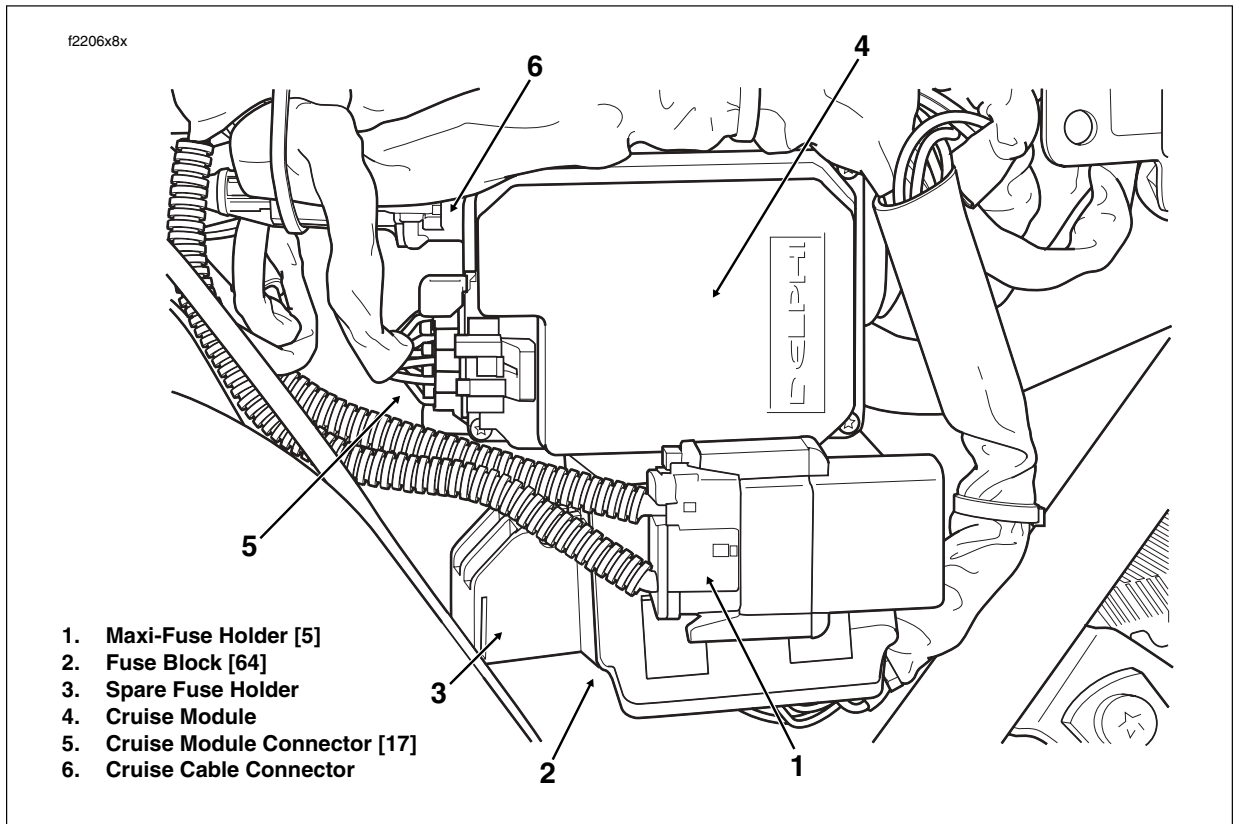

Figure B-47. Cruise Control Module (Under Left Side Cover)

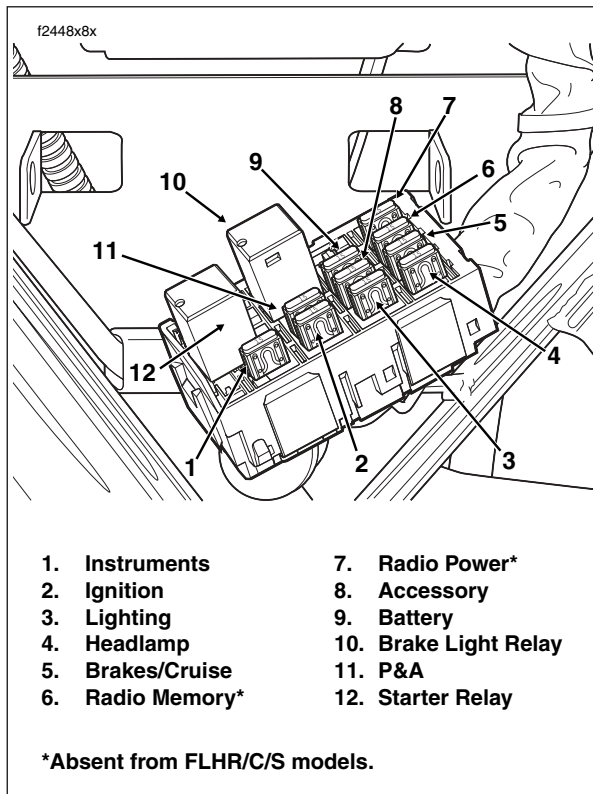

Figure B-48. Fuse Blocks - FLHX, FLHTC/U, FLTR (Under Left Side Cover)

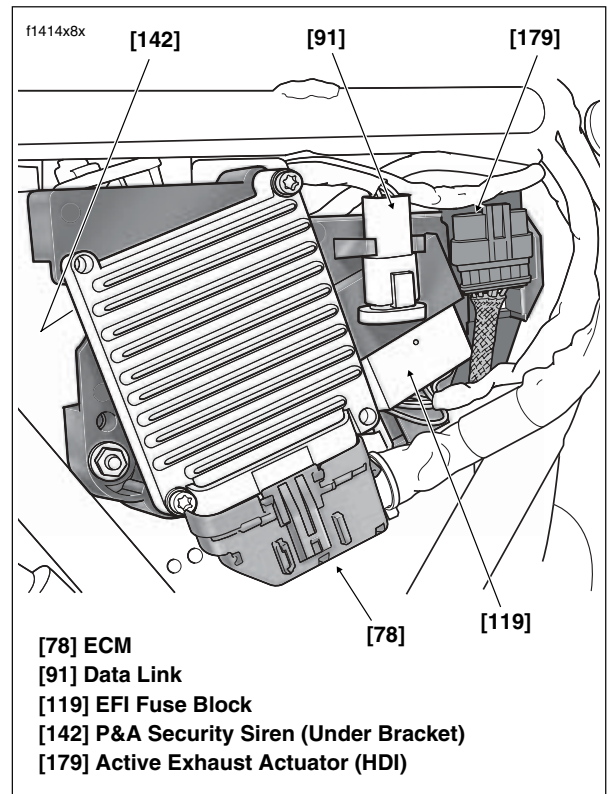

Figure B-49. Under Right Side Cover

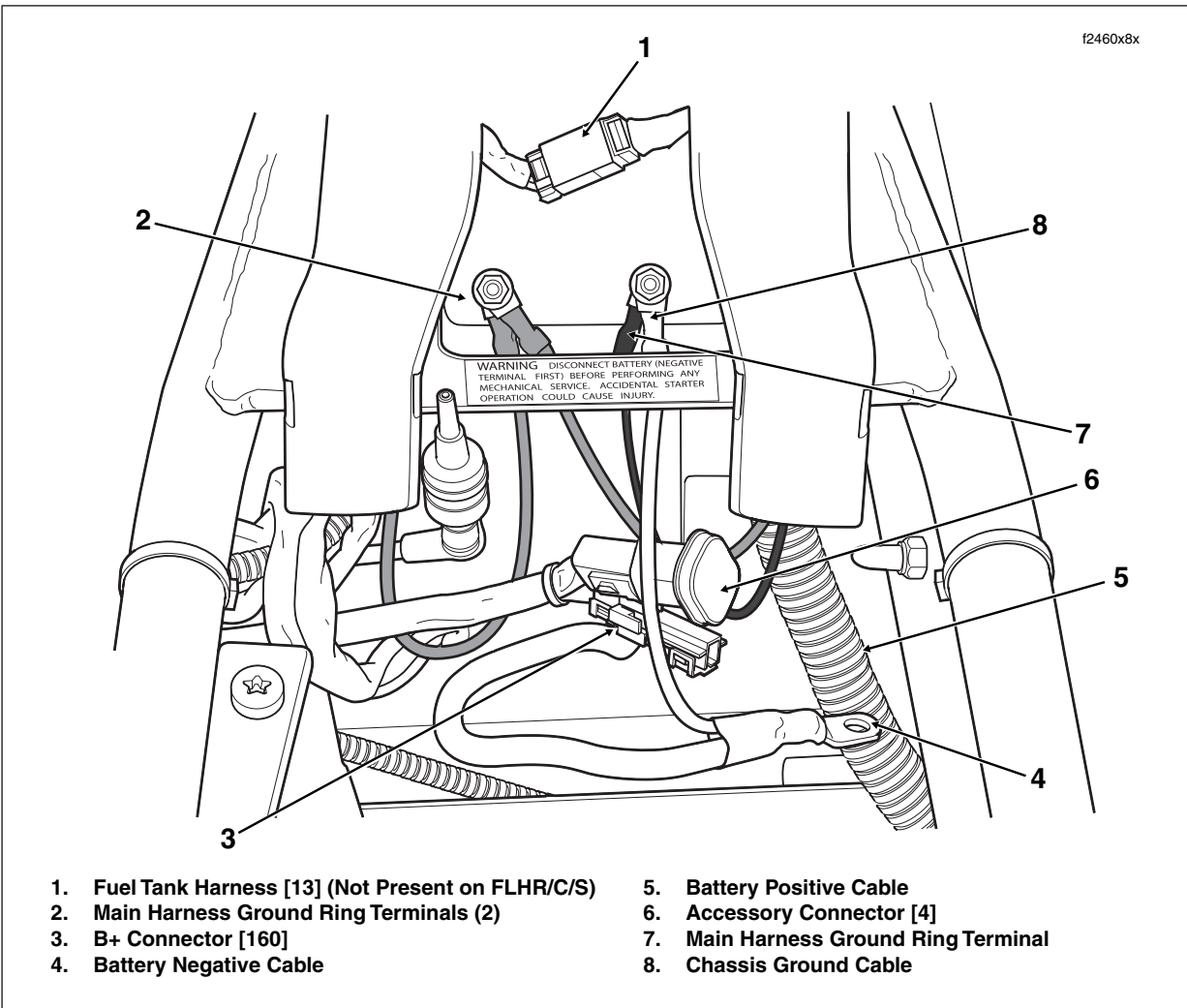

Figure B-50. Electrical Connectors - Upper Frame Crossmember (Under Seat)

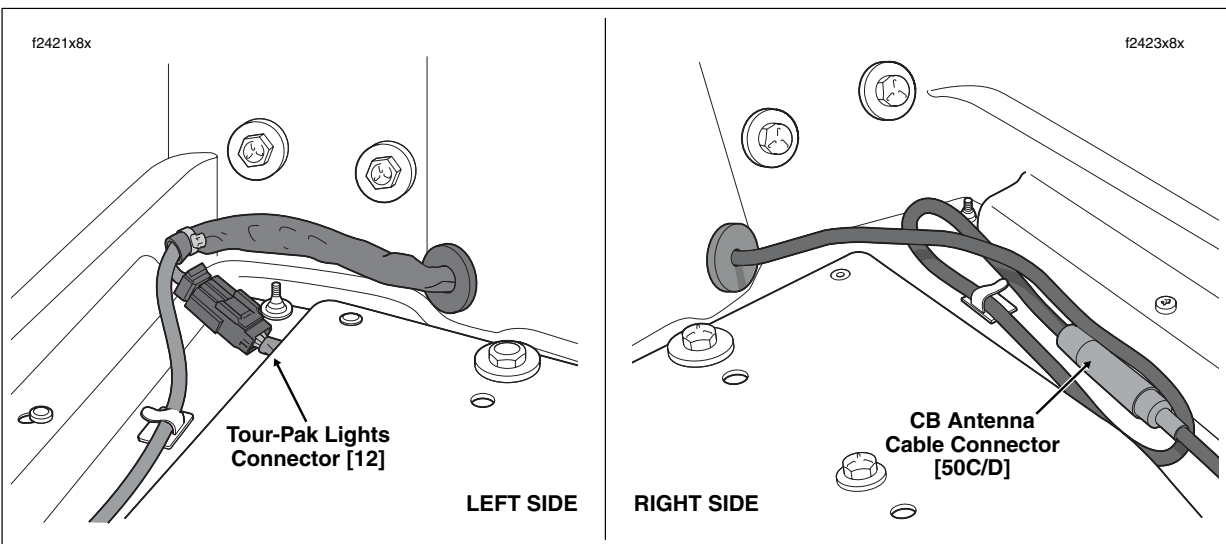

Figure B-51. Tour-Pak Connectors

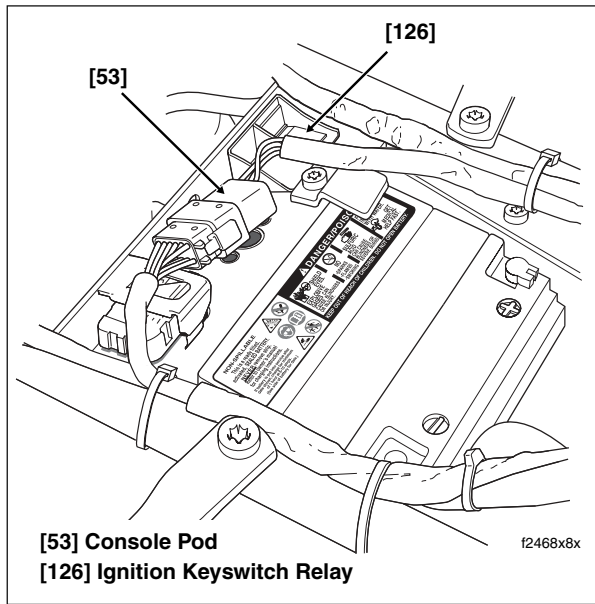

Figure B-52. Frame Crossmember (Under Seat)

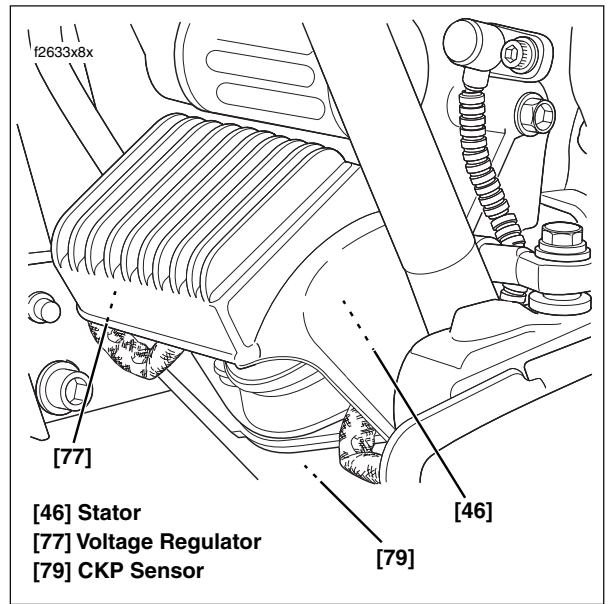

Figure B-54. Voltage Regulator (Left Side View)

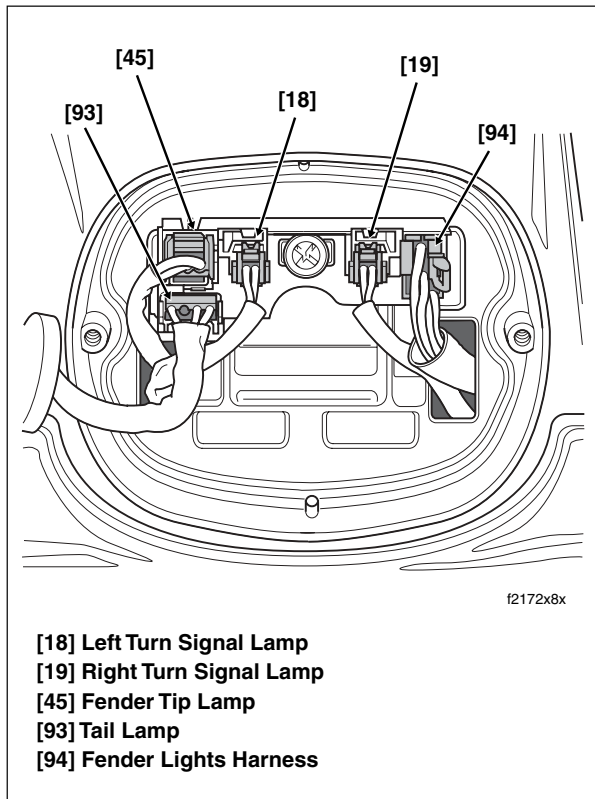

Figure B-53. Rear Fender Lights Assembly

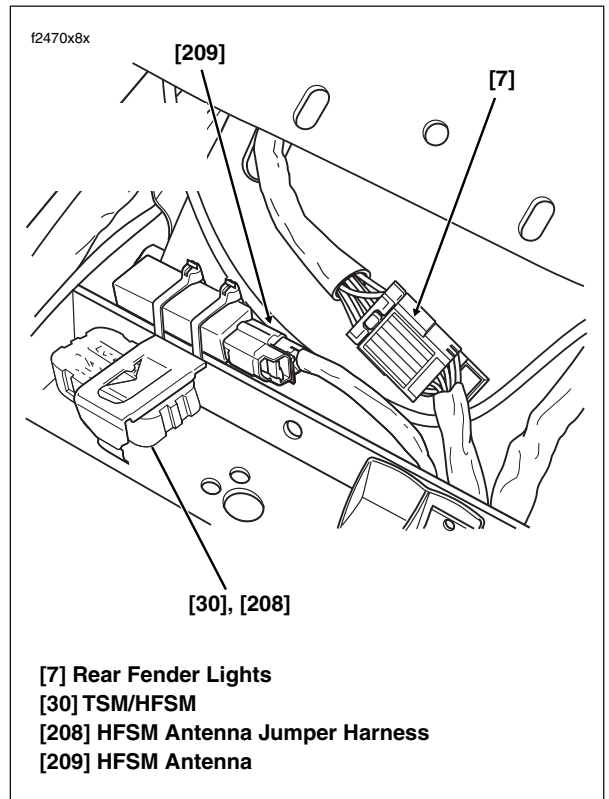

Figure B-55. Rear Fender (Under Seat)

No.	Description	Type	Location	Fig.
[1]	Main to Interconnect Harness	16 - Place Molex (Black)	Inner Fairing - Below Radio (Right Side)	57
[2]	Main to Interconnect Harness	12 - Place Molex (Gray)	Inner Fairing - Below Radio (Right Side)	57
[4]	Accessory	4 - Place Deutsch	Upper Frame Crossmember (Under Seat)	50
[5]	Maxi-Fuse	2 - Place Packard	Under Left Side Cover	47
[7]	Rear Fender Lights Harness	8 - Place Multilock	Top of Rear Fender (Under Seat)	55
[13]	Fuel Tank Harness	4 - Place Multilock	Behind Fuel Tank (Under Seat)	50
[15]	Main to Interconnect Harness	4 - Place Packard	Inner Fairing - Below Radio (Right Side)	57
[17]	Cruise Control Module	10 - Place Packard	Under Left Side Cover	47
[18]	Left Rear Turn Signal	2 - Place Multilock	Circuit Board Under Tail Lamp Assembly	53
[19]	Right Rear Turn Signal	2 - Place Multilock	Circuit Board Under Tail Lamp Assembly	53
[21]	Indicator Lights	10 - Place Multilock	Inside Instrument Nacelle (Under Bezel)	56
[22]	Interconnect to Right Handlebar Switches	12 - Place Molex (Black)	Inner Fairing - Left Side of Radio Bracket	57
[24]	Interconnect to Left Handlebar Switches	16 - Place Molex (Gray)	Inner Fairing - Left Side of Radio Bracket	57
[27]	Radio	23 - Place Amp	Inner Fairing - Back of Radio (Right Side)	57
[30]	TSM/HFSM	12 - Place Deutsch (Gray)	Crossmember at Rear of Battery Box (Under Seat)	55
[31L]	Left Front Turn Signal	3 - Place Multilock	Inner Fairing - Left Side	57
[31R]	Right Front Turn Signal	3 - Place Multilock	Inner Fairing - Right Side	57
[33]	Ignition/Light Key Switch	3 - Place Packard	Front of Ignition Switch Housing	-
[34]	Right Front Speaker	Spade Contacts	Inner Fairing (Back of Speaker)	-
[35]	Left Front Speaker	Spade Contacts	Inner Fairing (Back of Speaker)	-
[38]	Headlamp	Headlamp Connector	Inner Fairing (Back of Headlamp)	57
[39]	Speedometer	12 - Place Packard (Black)	Inside Instrument Nacelle (Back of Speedometer)	56
[45]	Rear Fender Tip Lamp (DOM)	3 - Place Multilock	Circuit Board Under Tail Lamp Assembly	53
[46]	Stator	3 - Place Lyall	Bottom of Voltage Regulator (Left Side)	54

FLTR Continued ...

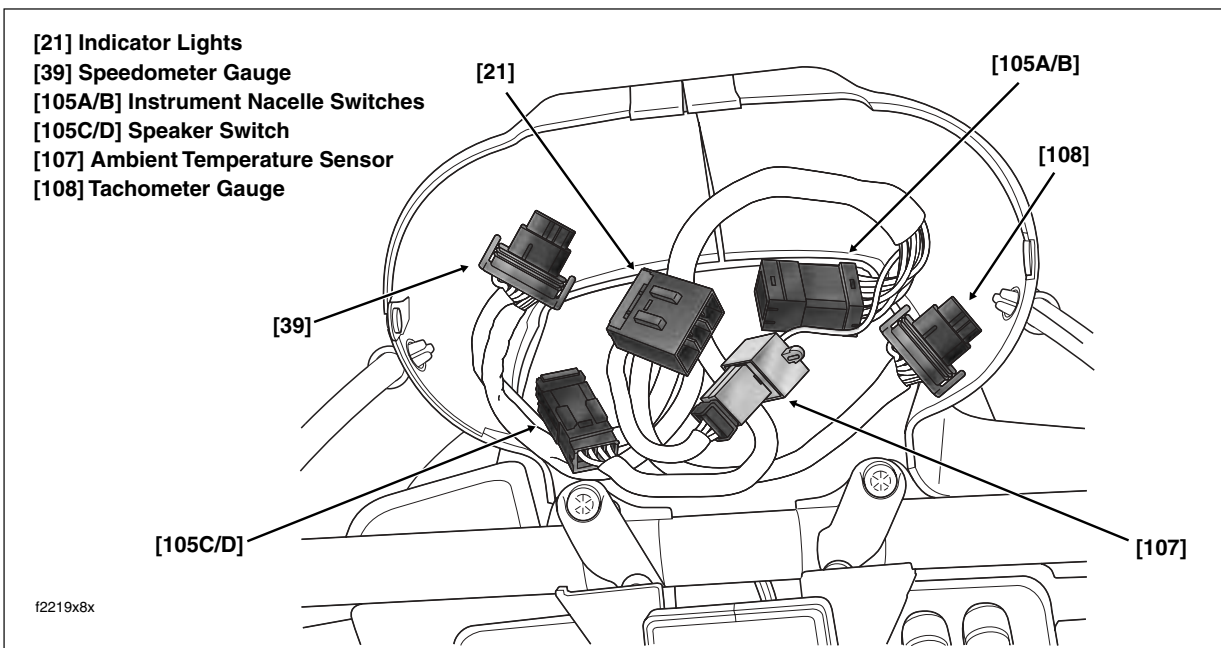

Figure B-56. Instrument Nacelle Connectors (FLTR)

FLTR (Continued)

No.	Description	Type	Location	Fig.
[51]	Radio Antenna Cable	-	Inner Fairing - Back of Radio (Left Side)	57
[64]	Fuse Block	Packard	Under Left Side Cover	47,48
[65]	VSS	3 - Place Delphi	Top of Transmission Case (Under Starter)	-
[75]	Cruise Roll-Off Switch	Spade Contacts	Right Side of Steering Head	-
[77]	Voltage Regulator	2 - Place Lyall	Bottom of Voltage Regulator (Right Side)	54
[78]	ECM	36 - Place Packard	Under Right Side Cover	49
[79]	CKP Sensor	2 - Place Deutsch	Electrical Caddy at Bottom of Lower Frame Crossmember	54
[80]	MAP Sensor	3 - Place Packard	Top of Induction Module	-
[83]	Ignition Coil	4 - Place Delphi	Below Fuel Tank (Left Side)	-
[84]	Front Injector	2 - Place Delphi	Below Fuel Tank (Left Side)	-
[85]	Rear Injector	2 - Place Delphi	Below Fuel Tank (Left Side)	-
[87]	IAC	4 - Place Delphi	Below Fuel Tank (Right Side)	-

FLTR Continued ...

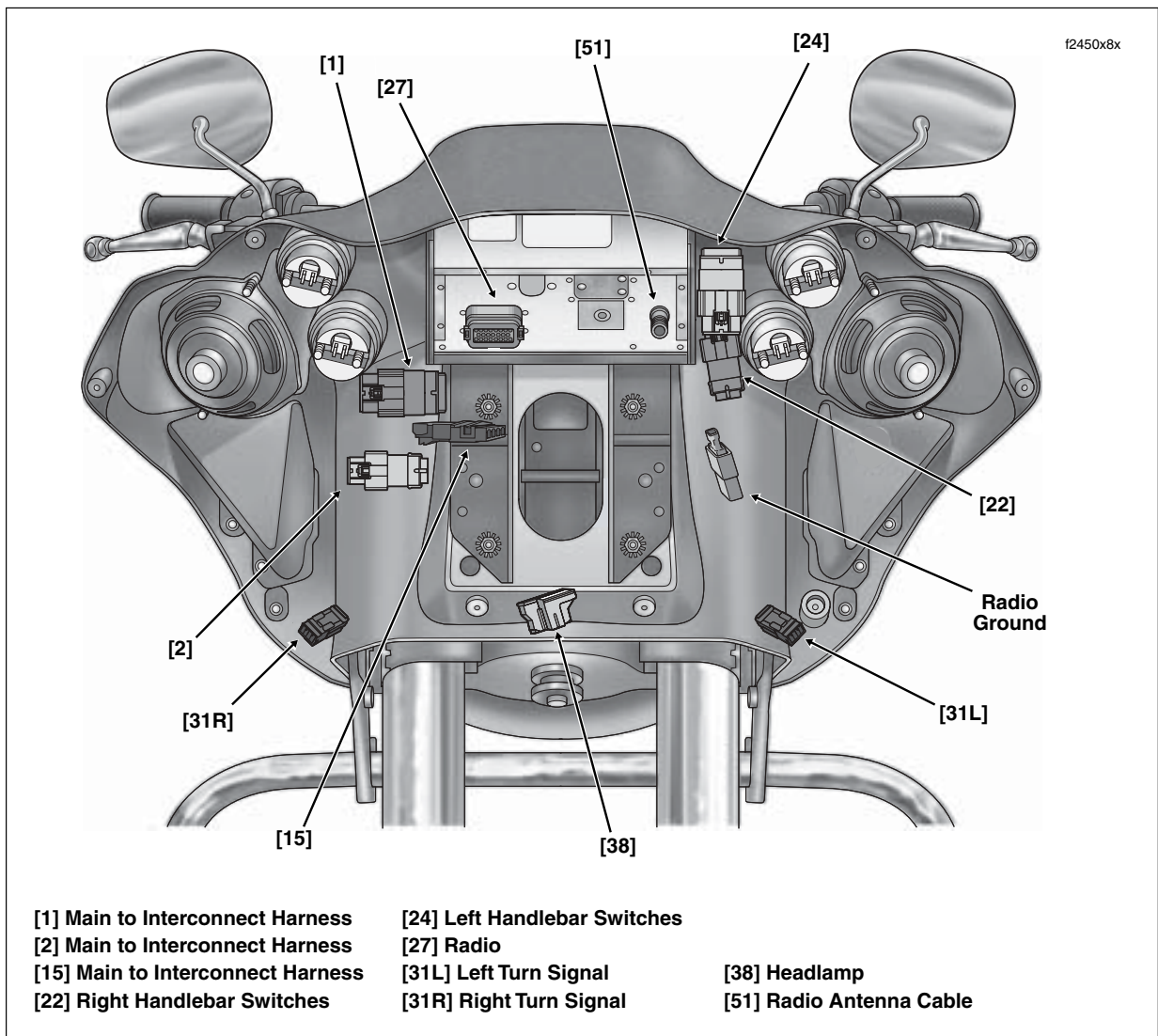

Figure B-57. Inner Fairing Connectors (FLTR)

FLTR (Continued)

No.	Description	Type	Location	Fig.
[88]	TP Sensor	3 - Place Delphi	Below Fuel Tank (Right Side)	-
[89]	IAT Sensor	2 - Place Delphi	Below Fuel Tank (Right Side)	-
[90]	ET Sensor	2 - Place Delphi	Back of Front Cylinder (Left Side)	-
[91]	Data Link	4 - Place Deutsch	Under Right Side Cover	49
[93]	Tail Lamp	4 - Place Multilock	Circuit Board Under Tail Lamp Assembly	53
[94]	Rear Fender Lights Harness to Circuit Board	6 - Place Multilock	Circuit Board Under Tail Lamp Assembly	53
[105]	Instrument Nacelle Switches			
	Interconnect to Nacelle Switch Harness [105A, 105B]	12 - Place Multilock	Inside Instrument Nacelle (Under Bezel)	56
	Nacelle Switch Harness to Speaker Switch [105C, 105D]	4 - Place Multilock	Inside Instrument Nacelle (Under Bezel)	56
[107]	Ambient Air Temperature Sensor	3 - Place Multilock	Inside Instrument Nacelle (Under Bezel)	56
[108]	Tachometer	12 - Place Packard (Gray)	Inside Instrument Nacelle (Back of Tachometer)	56
[110]	Voltmeter Lamp	Spade Connector	Inner Fairing (Back of Voltmeter)	-
[111]	Voltmeter	Spade Connector	Inner Fairing (Back of Voltmeter)	-
[112]	Oil Pressure Gauge Lamp	Spade Connector	Inner Fairing (Back of Oil Pressure Gauge)	-
[113]	Oil Pressure Gauge	Spade Connector	Inner Fairing (Back of Oil Pressure Gauge)	-
[114]	Air Temperature Gauge Lamp	Spade Connector	Inner Fairing (Back of Air Temperature Gauge)	-
[115]	Air Temperature Gauge	Spade Connector	Inner Fairing (Back of Air Temperature Gauge)	-
[116]	Fuel Gauge Lamp	Spade Connector	Inner Fairing (Back of Fuel Gauge)	-
[117]	Fuel Gauge	Spade Connector	Inner Fairing (Back of Fuel Gauge)	-
[119]	EFI Fuses	Fuse Terminals	Fuse Block (Under Right Side Cover)	49
[121]	Rear Brake Light Switch	Spade Terminals	Bottom of Rear Frame Downtube (Right Side)	-
[122]	Horn	Spade Terminals	Between Cylinders (Left Side)	-
[123]	Starter Relay	Relay Connector	Fuse Block (Under Left Side Cover)	48
[124]	Brake Light Relay	Relay Connector	Fuse Block (Under Left Side Cover)	48
[126]	Ignition Keyswitch Relay	Relay Connector	Crossmember at Rear of Battery Box (Under Seat)	52
[128]	Starter Solenoid	Spade Terminals	Top of Starter	-
[129]	Harness Grounds	Ring Terminals	Upper Frame Crossmember (Under Seat)	50
[131]	Neutral Switch	Post Terminals	Top of Transmission (Right Side)	-
[132]	Cigarette Lighter	Spade Terminals	Inner Fairing	-
[135]	EFI System Relay	Relay Connector	Fuse Block (Under Right Side Cover)	49
[137]	O ₂ Sensor Rear Exhaust Header	2 - Place Amp (Tyco)	Under Chrome Starter Cover	-
[138]	O ₂ Sensor Front Exhaust Header	2 - Place Amp (Tyco)	Back of Cross Brace Between Front Frame Downtubes (Left Side)	-
[139]	Oil Pressure Sender	4 - Place Delphi	Front Right Crankcase	-
[141]	Fuel Pump and Fuel Level Sender	4 - Place Packard	Top of Canopy (Under Console)	-
[142]	Security Siren (Optional)	3 - Place Delphi	Under Right Side Cover (Behind Electrical Bracket)	49
[160]	B+	1 - Place Packard	Upper Frame Crossmember (Under Seat)	50
[178]	Active Intake Solenoid	2 - Place Amp (Tyco)	Back of Air Cleaner Backplate	-
[179]	Active Exhaust Actuator	5 - Place Amp (Tyco)	Domestic (Not Used): Under Right Side Cover	49
			HDI: Under Right Side Cover (Behind Electrical Bracket)	-
[208]	HFSM Antenna Jumper Harness	4 - Place Deutsch	TSM/HFSM in Crossmember at Rear of Battery Box (Under Seat)	55
[209]	HFSM Antenna	2 - Place Molex	Top of Rear Fender (Under Seat)	55

FLHR/C/S

No.	Description	Type	Location	Fig.
[4]	Accessory	4 - Place Deutsch	Upper Frame Crossmember (Under Seat)	50
[5]	Maxi-Fuse	2 - Place Packard	Under Left Side Cover	47
[7]	Rear Fender Lights Harness	8 - Place Multilock	Top of Rear Fender (Under Seat)	55
[18]	Left Rear Turn Signal	2 - Place Multilock	Circuit Board Under Tail Lamp Assembly	53
[19]	Right Rear Turn Signal	2 - Place Multilock	Circuit Board Under Tail Lamp Assembly	53
[21]	Indicator Lights	8 - Place Deutsch	Under Console	59
[22]	Right Handlebar Switches	6 - Place Molex (Black)	Inside Headlamp Nacelle - Fork Stem Nut Lock Plate (Right Side)	58
[24]	Left Handlebar Switches	8 - Place Molex (Gray)	Inside Headlamp Nacelle - Fork Stem Nut Lock Plate (Left Side)	58
[30]	TSM/HFSM	12 - Place Deutsch	Crossmember at Rear of Battery Box (Under Seat)	55
[31]	Front Turn Signals	6 - Place Multilock	Inside Headlamp Nacelle - Fork Stem Nut Lock Plate (Left Side)	58
[32]	Front Fender Tip Lamp Jumper Harness (DOM)	2 - Place Multilock (Black)	Inside Headlamp Nacelle	58
[33]	Ignition/Light Key Switch	3 - Place Packard	Under Console	59
[38]	Headlamp	Headlamp Connector	Inside Headlamp Nacelle	58
[39]	Speedometer	12 - Place Packard	Back of Speedometer (Under Console)	59
[45]	Rear Fender Tip Lamp (DOM)	3 - Place Multilock	Circuit Board Under Tail Lamp Assembly	53
[46]	Stator	3 - Place Lyall	Bottom of Voltage Regulator (Left Side)	54
[64]	Fuse Block	Packard	Under Left Side Cover	47,48
[65]	VSS	3 - Place Delphi	Top of Transmission Case (Under Starter)	-
[67]	Accessory Switch	4 - Place Amp	Inside Headlamp Nacelle	58
[73]	Auxiliary Lamps	2 - Place Multilock (White)	Inside Headlamp Nacelle	58
[75]	Cruise Roll-Off Switch **	Spade Contacts	Right Side of Steering Head	-
[77]	Voltage Regulator	2 - Place Lyall	Bottom of Voltage Regulator (Right Side)	54
[78]	ECM	36 - Place Packard	Under Right Side Cover	49
[79]	CKP Sensor	2 - Place Deutsch	Electrical Caddy at Bottom of Lower Frame Crossmember	54
[80]	MAP Sensor	3 - Place Packard	Top of Induction Module	-

FLHR/C/S Continued ...

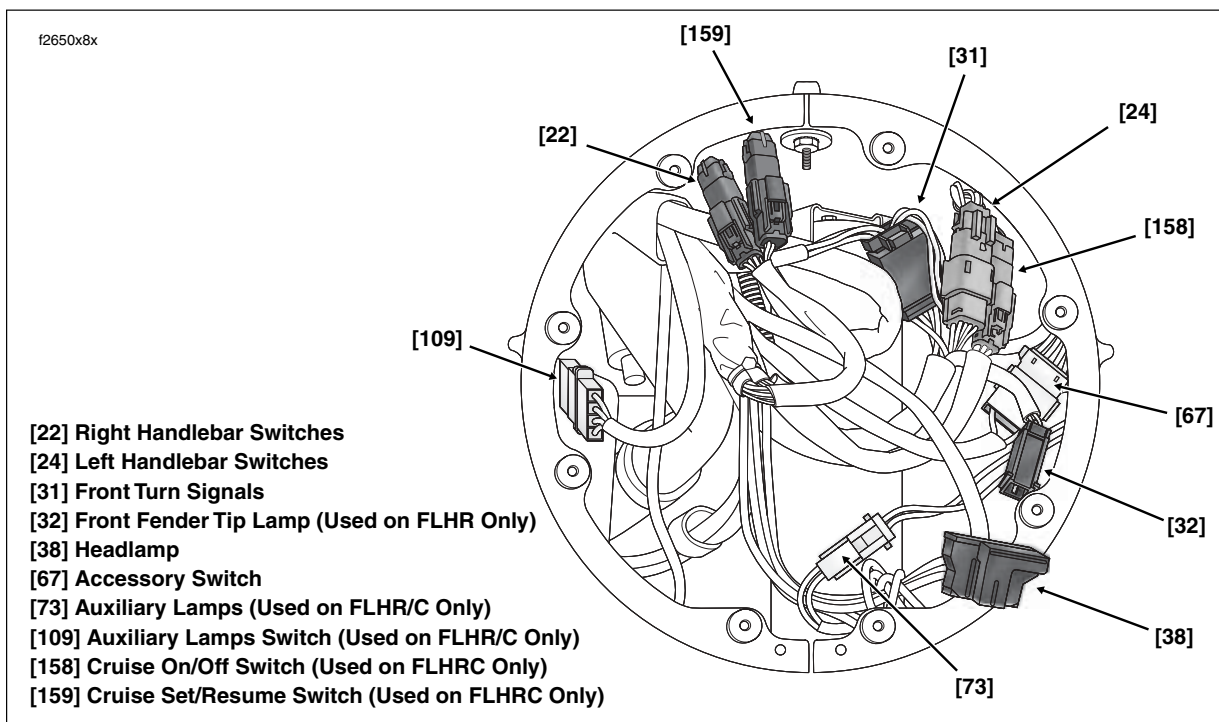

Figure B-58. Headlamp Nacelle Connectors (FLHR/C/S)

FLHR/C/S (Continued)

No.	Description	Type	Location	Fig.
[83]	Ignition Coil	4 - Place Delphi	Below Fuel Tank (Left Side)	-
[84]	Front Injector	2 - Place Delphi	Below Fuel Tank (Left Side)	-
[85]	Rear Injector	2 - Place Delphi	Below Fuel Tank (Left Side)	-
[87]	IAC	4 - Place Delphi	Below Fuel Tank (Right Side)	-
[88]	TP Sensor	3 - Place Delphi	Below Fuel Tank (Right Side)	-
[89]	IAT Sensor	2 - Place Delphi	Below Fuel Tank (Right Side)	-
[90]	ET Sensor	2 - Place Delphi	Back of Front Cylinder (Left Side)	-
[91]	Data Link	4 - Place Deutsch	Under Right Side Cover	49
[93]	Tail Lamp	4 - Place Multilock	Circuit Board Under Tail Lamp Assembly	53
[94]	Rear Fender Lights Harness to Circuit Board	6 - Place Multilock	Circuit Board Under Tail Lamp Assembly	53
[108]	Optional Tachometer	1 - Place Amp	Inside Headlamp Nacelle	-
[109]	Auxiliary Lamps Switch	4 - Place Amp	Inside Headlamp Nacelle	58
[117]	Fuel Gauge	4 - Place Multilock	Below Fuel Tank (Left Side)	-
[119]	EFI Fuses	Fuse Terminals	Fuse Block (Under Right Side Cover)	49
[120]	Oil Pressure Switch	Post Terminal	Front Right Crankcase	-
[121]	Rear Brake Light Switch	Spade Terminals	Bottom of Rear Frame Downtube (Right Side)	-
[122]	Horn	Spade Terminals	Between Cylinders (Left Side)	-
[123]	Starter Relay	Relay Connector	Fuse Block (Under Left Side Cover)	48
[124]	Brake Light Relay	Relay Connector	Fuse Block (Under Left Side Cover)	48
[126]	Ignition Keyswitch Relay	Relay Connector	Crossmember at Rear of Battery Box (Under Seat)	52
[128]	Starter Solenoid	Spade Terminals	Top of Starter	-
[129]	Harness Grounds	Ring Terminals	Upper Frame Crossmember (Under Seat)	50
[131]	Neutral Switch	Post Terminals	Top of Transmission (Right Side)	-
[135]	EFI System Relay	Relay Connector	Fuse Block (Under Right Side Cover)	49
[137]	O ₂ Sensor Rear Exhaust Header	2 - Place Amp (Tyco)	Under Chrome Starter Cover	-
[138]	O ₂ Sensor Front Exhaust Header	2 - Place Amp (Tyco)	Back of Cross Brace Between Front Frame Downtubes (Left Side)	-
[141]	Fuel Pump and Fuel Level Sender	4 - Place Packard	Top of Canopy (Under Console)	-
[142]	Security Siren (Optional)	3 - Place Delphi	Under Right Side Cover (Behind Electrical Bracket)	49
[143]	Front Fender Tip Lamp (DOM)	2 - Place Multilock (Black)	Under Front Fender Tip Lamp Bracket	-
[158]	Left Handlebar Switches (Cruise Control) **	3 - Place Molex (Gray)	Inside Headlamp Nacelle	58
[159]	Right Handlebar Switches (Cruise Control) **	3 - Place Molex (Black)	Inside Headlamp Nacelle	58
[160]	B+	1 - Place Packard	Upper Frame Crossmember (Under Seat)	50

FLHR/C/S Continued ...

** FLHRC Only

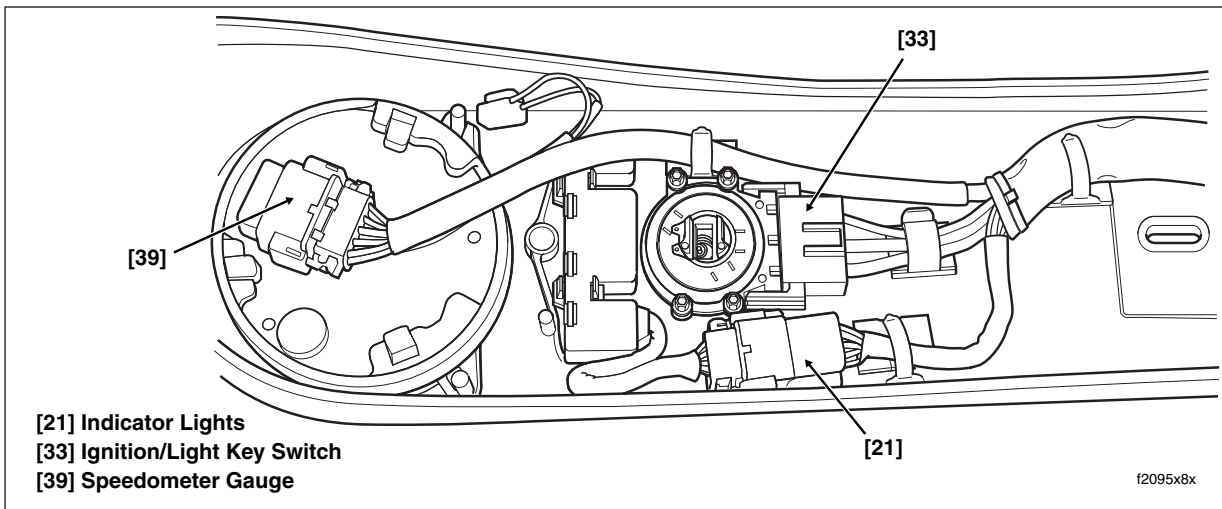

Figure B-59. Instrument Console Connectors (FLHR/C)

FLHR/C/S (Continued)

No.	Description	Type	Location	Fig.
[178]	Active Intake Solenoid	2 - Place Amp (Tyco)	Back of Air Cleaner Backplate	-
[179]	Active Exhaust Actuator	5 - Place Amp (Tyco)	Domestic (Not Used): Under Right Side Cover	49
			HDI: Under Right Side Cover (Behind Electrical Bracket)	-
[208]	HFSM Antenna Jumper Harness	4 - Place Deutsch	TSM/HFSM in Crossmember at Rear of Battery Box (Under Seat)	55
[209]	HFSM Antenna	2 - Place Molex	Top of Rear Fender (Under Seat)	55

NOTES

SUBJECT	PAGE NO.
FLHX, FLHT, FLHTC, FLHTCU	
Main Harness	B-45, B-47
Interconnect Harness	B-49
Tail Lamp, Auxiliary Lamps, Fender Tip Lamps, Directional Lamps and Tour-Pak Lights	B-51
Starting and Charging	B-53
Handlebar Switches and Indicator Lamps	B-55
Fairing Cap Switches	B-55
Radio, CB/Intercom and Rear Speakers	B-57
XM, Hands Free Phone and Navigation	B-57
FLTR	
Main Harness	B-45, B-47
Interconnect Harness	B-49
Tail Lamp and Directional Lamps	B-51
Starting and Charging	B-53
Handlebar Switches and Indicator Lamps	B-55
Instrument Nacelle Switches	B-55
Radio	B-57
FLHR, FLHRC, FLHRS	
Main Harness	B-59, B-61
Starting and Charging	B-63
Handlebar Switches, Speedometer, Indicator Lamps, Tail Lamp, Auxiliary Lamps, Directional Lamps, Fender Tip Lamps and Aux Lamp/Accessory Switches	B-65
TLE Sidecar, TLE Ultra Sidecar	
Amplifier	B-67
Sidecar Speakers and Switches	B-67

NOTE

Harness Part No.'s may be included on some wiring diagrams. Use these numbers for reference only. ALWAYS REFER TO THE PARTS CATALOG WHEN ORDERING WIRING HARNESSSES.

NOTES

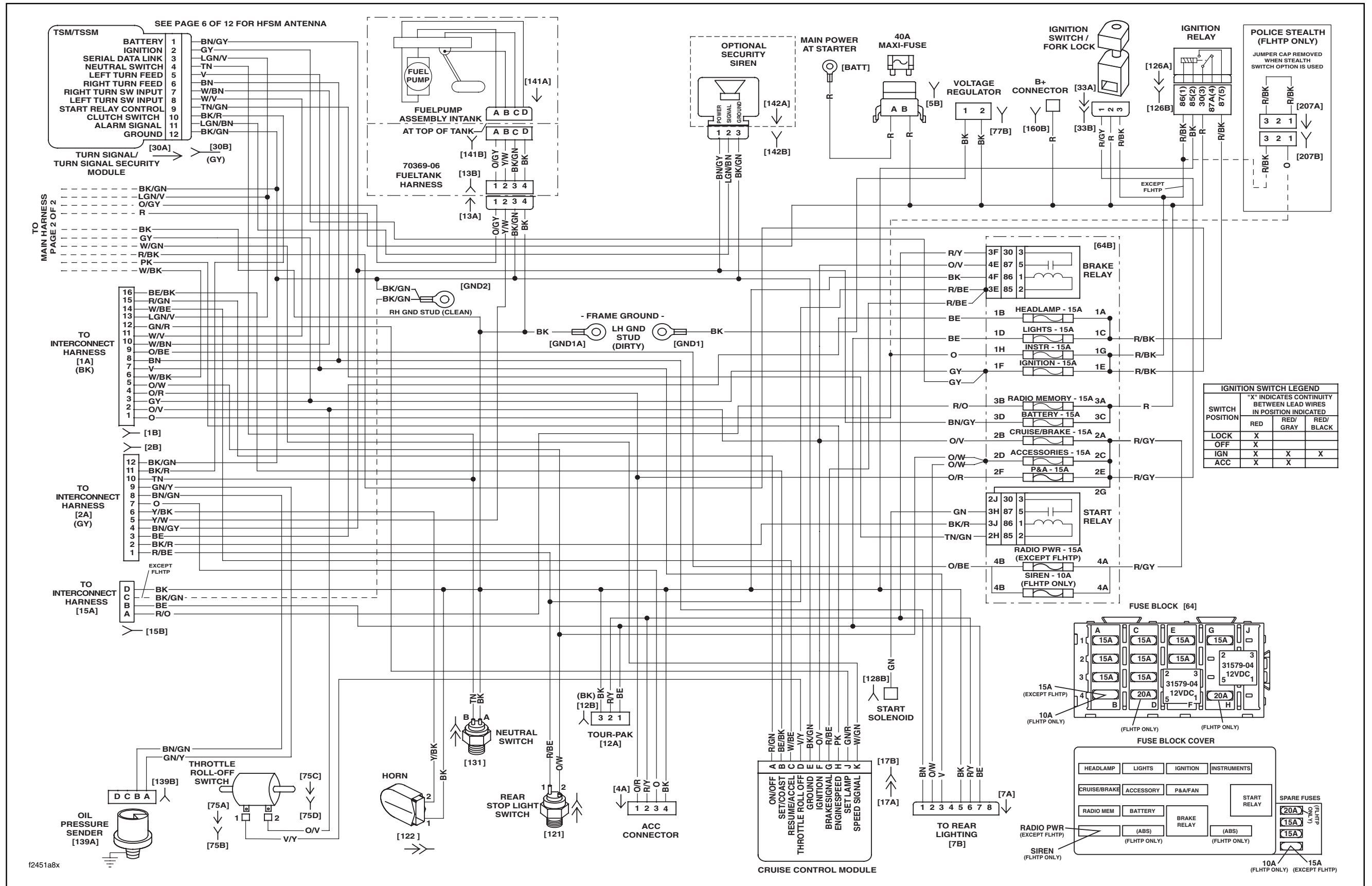

2007 FLHX, FLHT, FLHTC, FLHTCU and FLTR, DOMESTIC and INTERNATIONAL Models, Main Harness (Page 1 of 2)

**2007 FLHX, FLHT, FLHTC, FLHTCU and FLTR
DOMESTIC and INTERNATIONAL Models,
Main Harness (Page 1 of 2)**

**2007 FLHX, FLHT, FLHTC, FLHTCU and FLTR
DOMESTIC and INTERNATIONAL Models,
Main Harness (Page 1 of 2)**

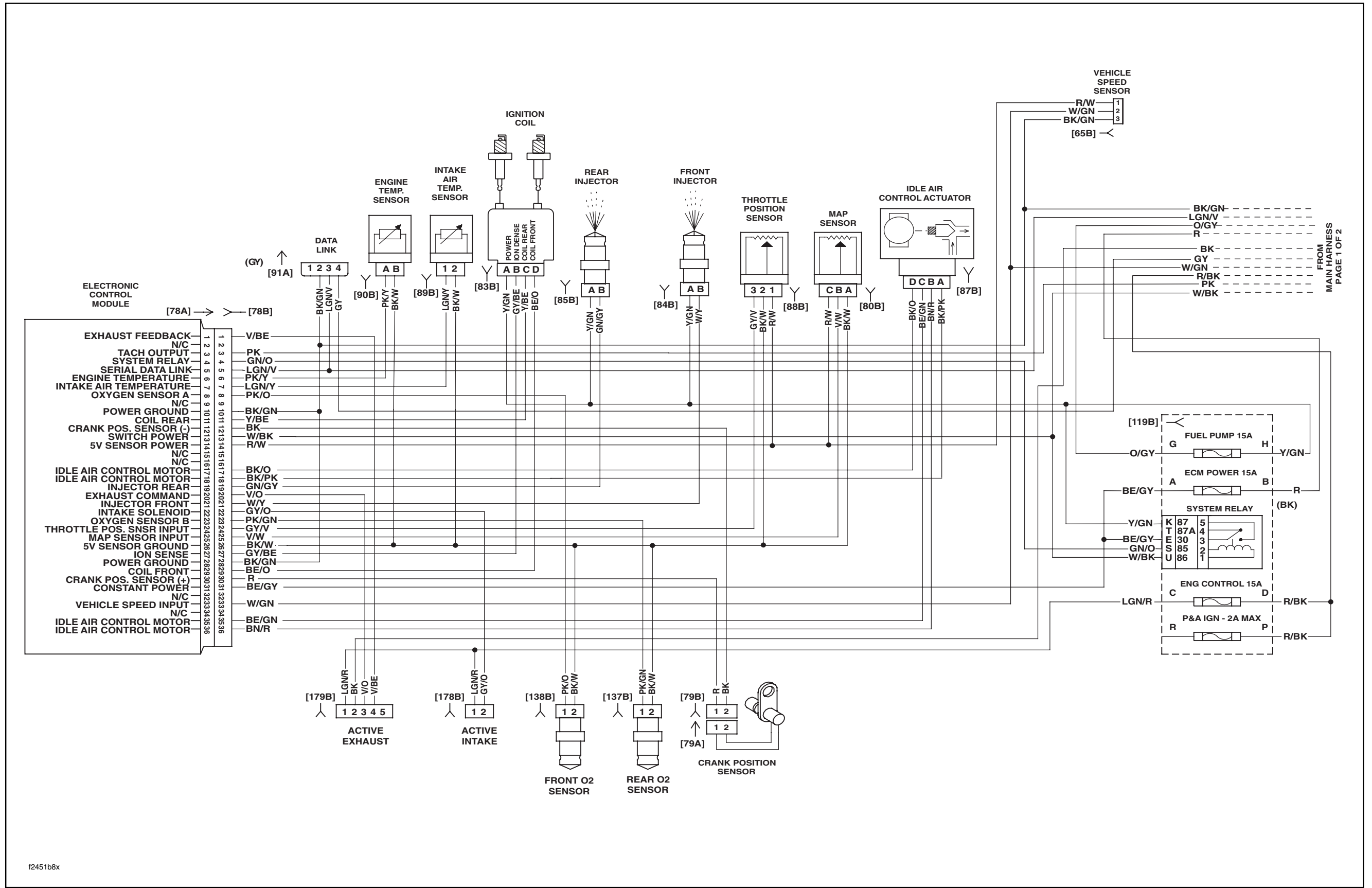

FROM MAIN HARNESS PAGE 1 OF 2

2007 FLHX, FLHT, FLHTC, FLHTCU and FLTR, DOMESTIC and INTERNATIONAL Models, Main Harness (Page 2 of 2)

**2007 FLHX, FLHT, FLHTC, FLHTCU and FLTR
DOMESTIC and INTERNATIONAL Models,
Main Harness (Page 2 of 2)**

**2007 FLHX, FLHT, FLHTC, FLHTCU and FLTR
DOMESTIC and INTERNATIONAL Models,
Main Harness (Page 2 of 2)**

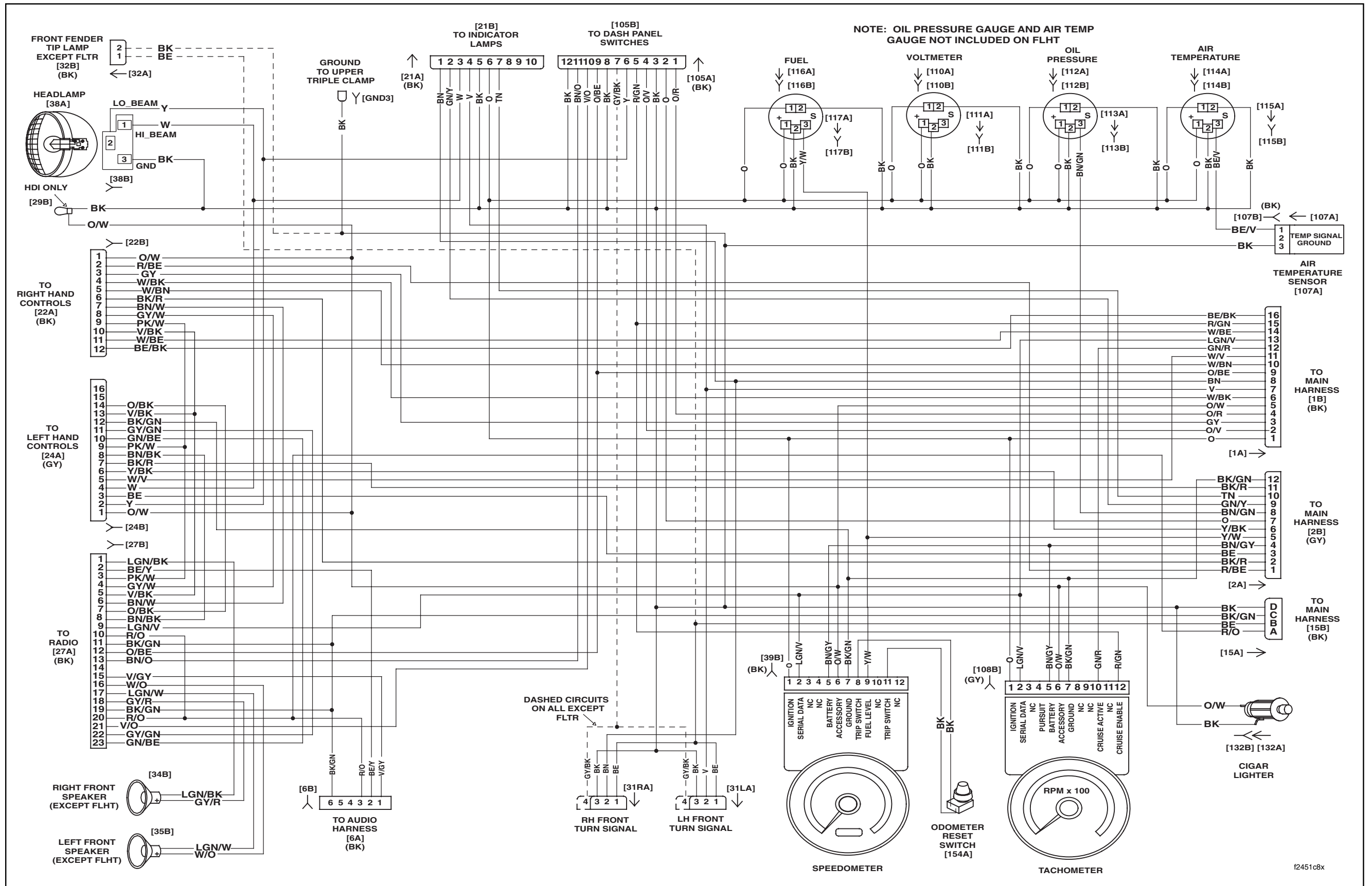

2007 FLHX, FLHT, FLHTC, FLHTCU and FLTR, DOMESTIC and INTERNATIONAL Models, Interconnect Harness

**2007 FLHX, FLHT, FLHTC, FLHTCU and FLTR
DOMESTIC and INTERNATIONAL Models,
Interconnect Harness**

**2007 FLHX, FLHT, FLHTC, FLHTCU and FLTR
DOMESTIC and INTERNATIONAL Models,
Interconnect Harness**

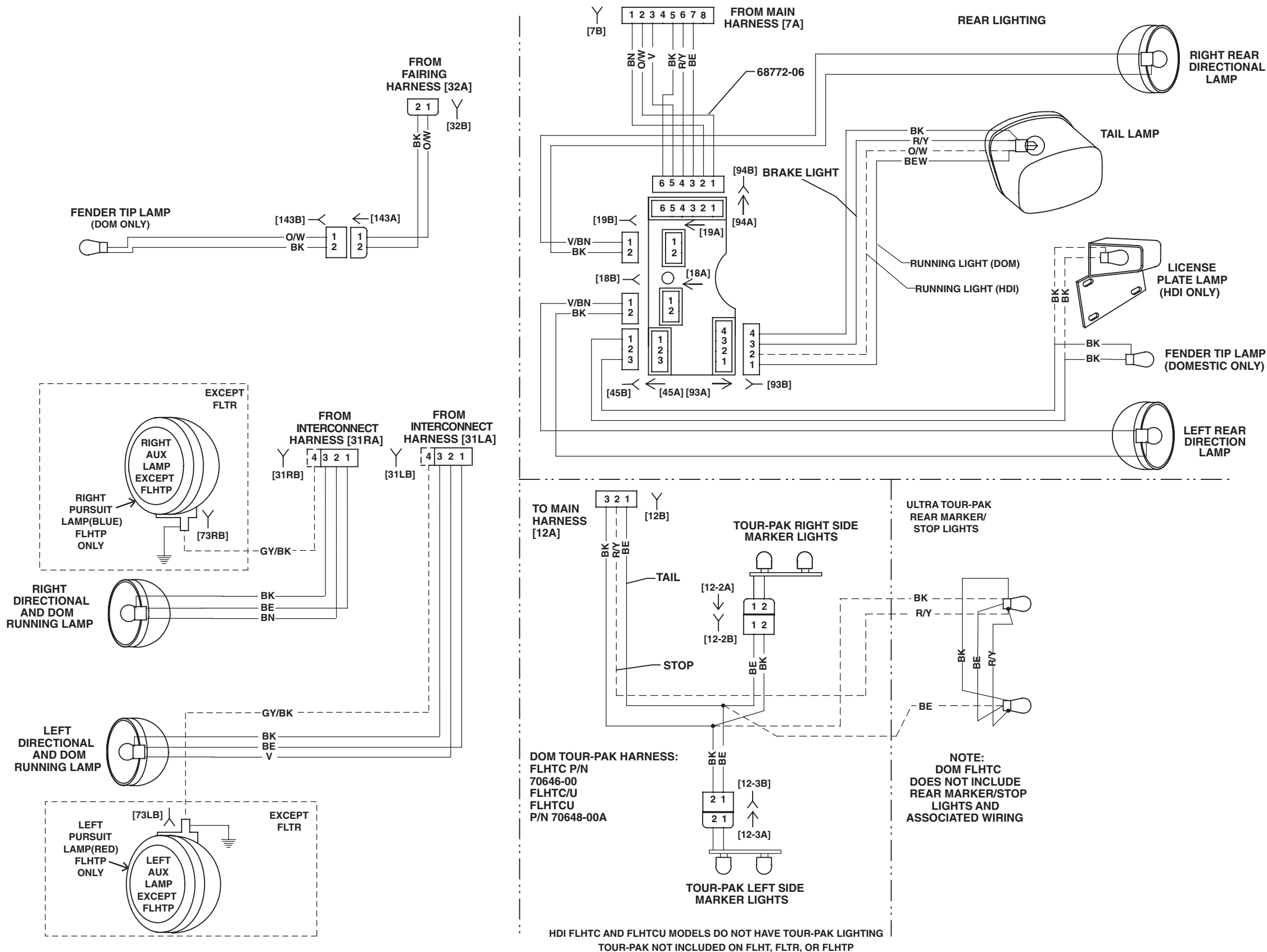

2007 FLHX, FLHT, FLHTC, FLHTCU and FLTR, DOMESTIC and INTERNATIONAL Models, Tail Lamp, Auxiliary Lamps, Fender Tip Lamps, Directional Lamps and Tour-Pak Lights

**2007 FLHX, FLHT, FLHTC, FLHTCU and FLTR
DOMESTIC and INTERNATIONAL Models,
Tail Lamp, Auxiliary Lamps, Fender Tip Lamps,
Directional Lamps and Tour-Pak Lights**

**2007 FLHX, FLHT, FLHTC, FLHTCU and FLTR
DOMESTIC and INTERNATIONAL Models,
Tail Lamp, Auxiliary Lamps, Fender Tip Lamps,
Directional Lamps and Tour-Pak Lights**

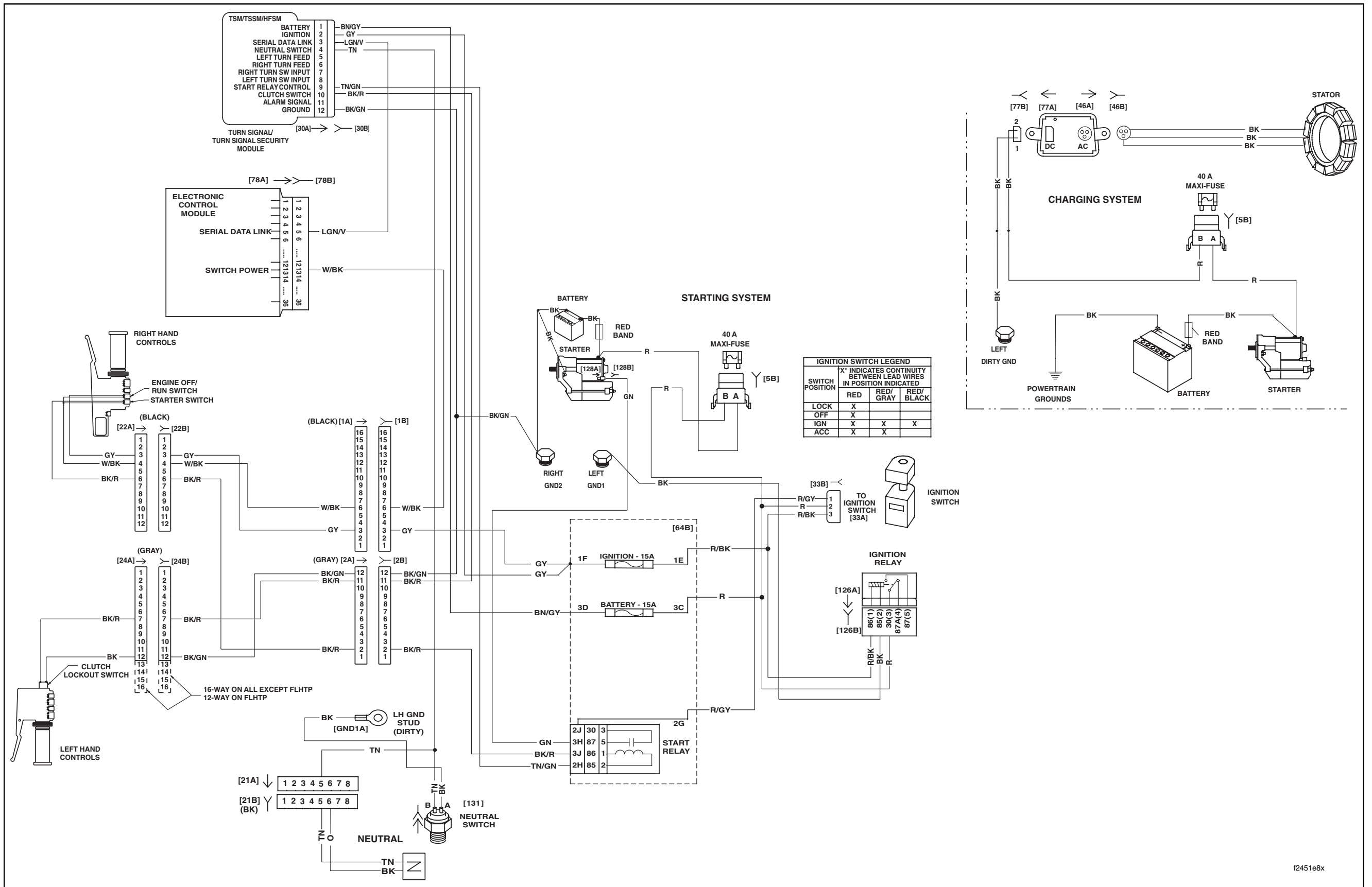

2007 FLHX, FLHT, FLHTC, FLHTCU and FLTR, DOMESTIC and INTERNATIONAL Models, Starting and Charging

**2007 FLHX, FLHT, FLHTC, FLHTCU and FLTR
DOMESTIC and INTERNATIONAL Models,
Starting and Charging**

**2007 FLHX, FLHT, FLHTC, FLHTCU and FLTR
DOMESTIC and INTERNATIONAL Models,
Starting and Charging**

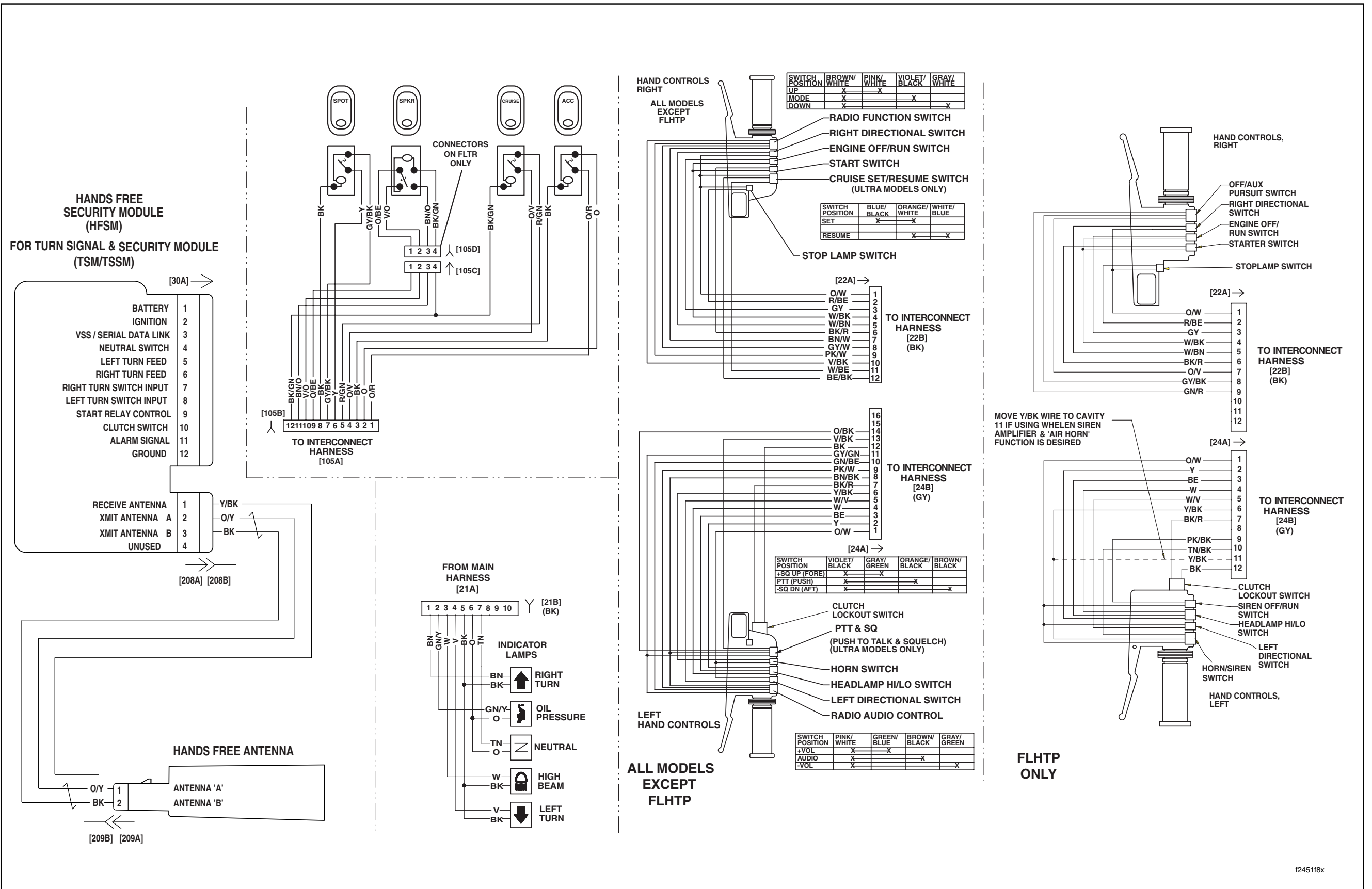

2007 FLHX, FLHT, FLHTC, FLHTCU and FLTR, DOMESTIC and INTERNATIONAL Models, Handlebar Switches, Indicator Lamps, Fairing Cap/Instrument Nacelle Switches and HFSSM/Antenna

**2007 FLHX, FLHT, FLHTC, FLHTCU and FLTR
DOMESTIC and INTERNATIONAL Models,
Handlebar Switches, Indicator Lamps,
Fairing Cap/Instrument Nacelle Switches
and HFSM/Antenna**

**2007 FLHX, FLHT, FLHTC, FLHTCU and FLTR
DOMESTIC and INTERNATIONAL Models,
Handlebar Switches, Indicator Lamps,
Fairing Cap/Instrument Nacelle Switches
and HFSM/Antenna**

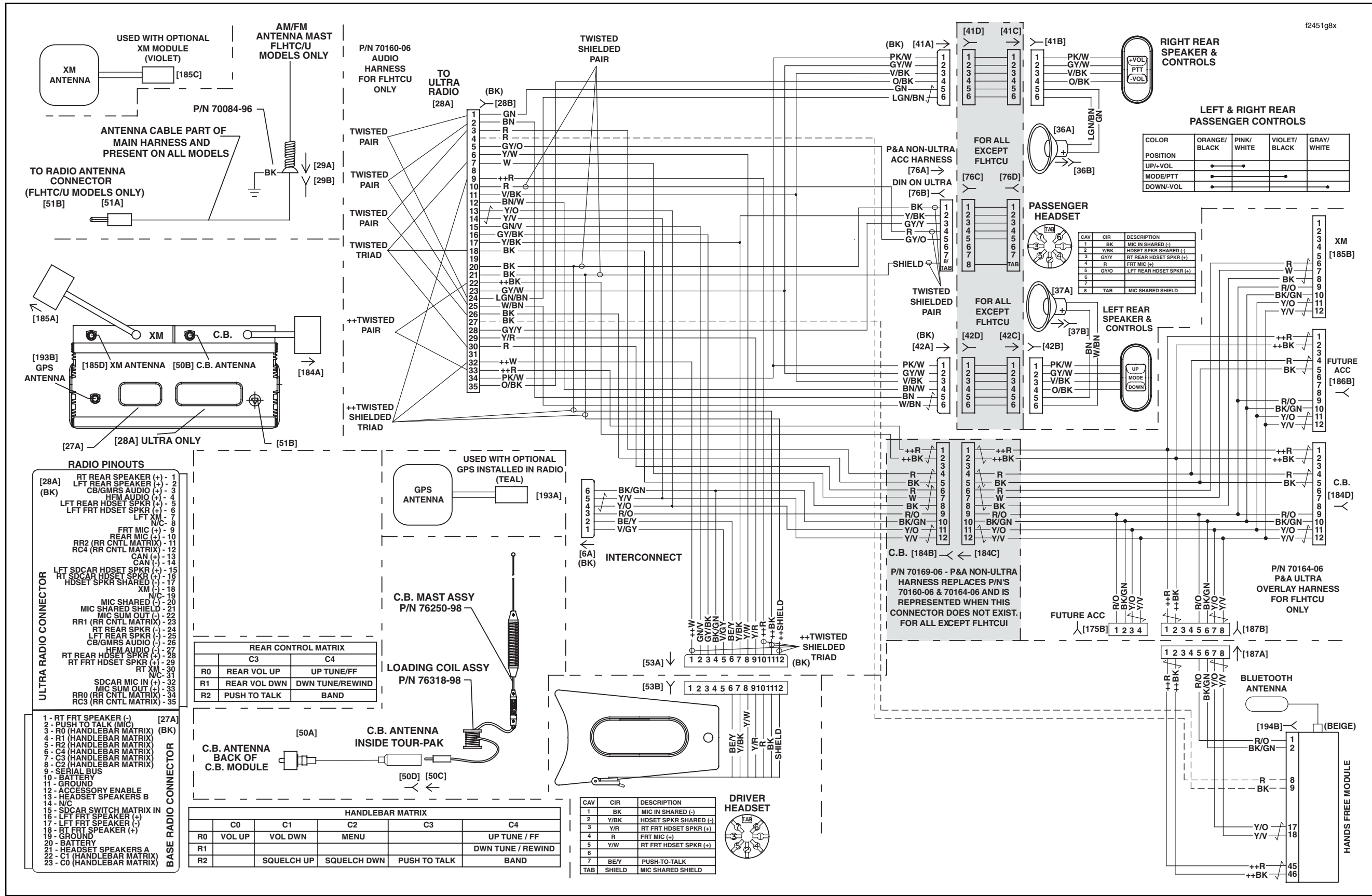

2007 FLHX, FLHTC, FLHTCU and FLTR, DOMESTIC and INTERNATIONAL Models, Radio, CB/Intercom, Rear Speakers, XM, Hands Free Phone and Navigation

**2007 FLHX, FLHTC, FLHTCU and FLTR
DOMESTIC and INTERNATIONAL Models,
Radio, CB/Intercom, Rear Speakers,
XM, Hands Free Phone and Navigation**

**2007 FLHX, FLHTC, FLHTCU and FLTR
DOMESTIC and INTERNATIONAL Models,
Radio, CB/Intercom, Rear Speakers
XM, Hands Free Phone and Navigation**

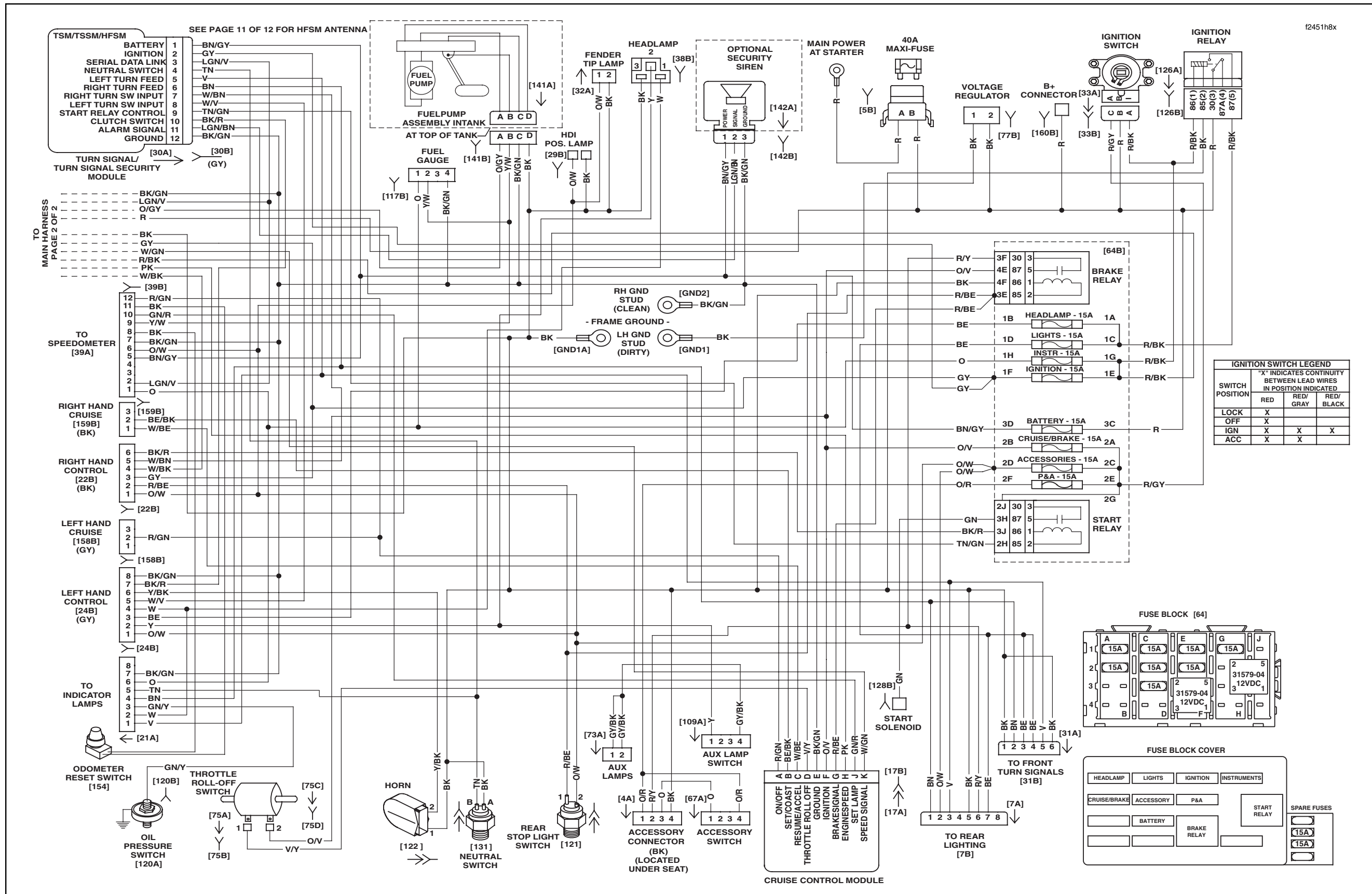

2007 FLHR, FLHRC and FLHRS, DOMESTIC and INTERNATIONAL Models, Main Harness (Page 1 of 2)

**2007 FLHR, FLHRC and FLHRS,
DOMESTIC and INTERNATIONAL Models,
Main Harness (Page 1 of 2)**

**2007 FLHR, FLHRC and FLHRS,
DOMESTIC and INTERNATIONAL Models,
Main Harness (Page 1 of 2)**

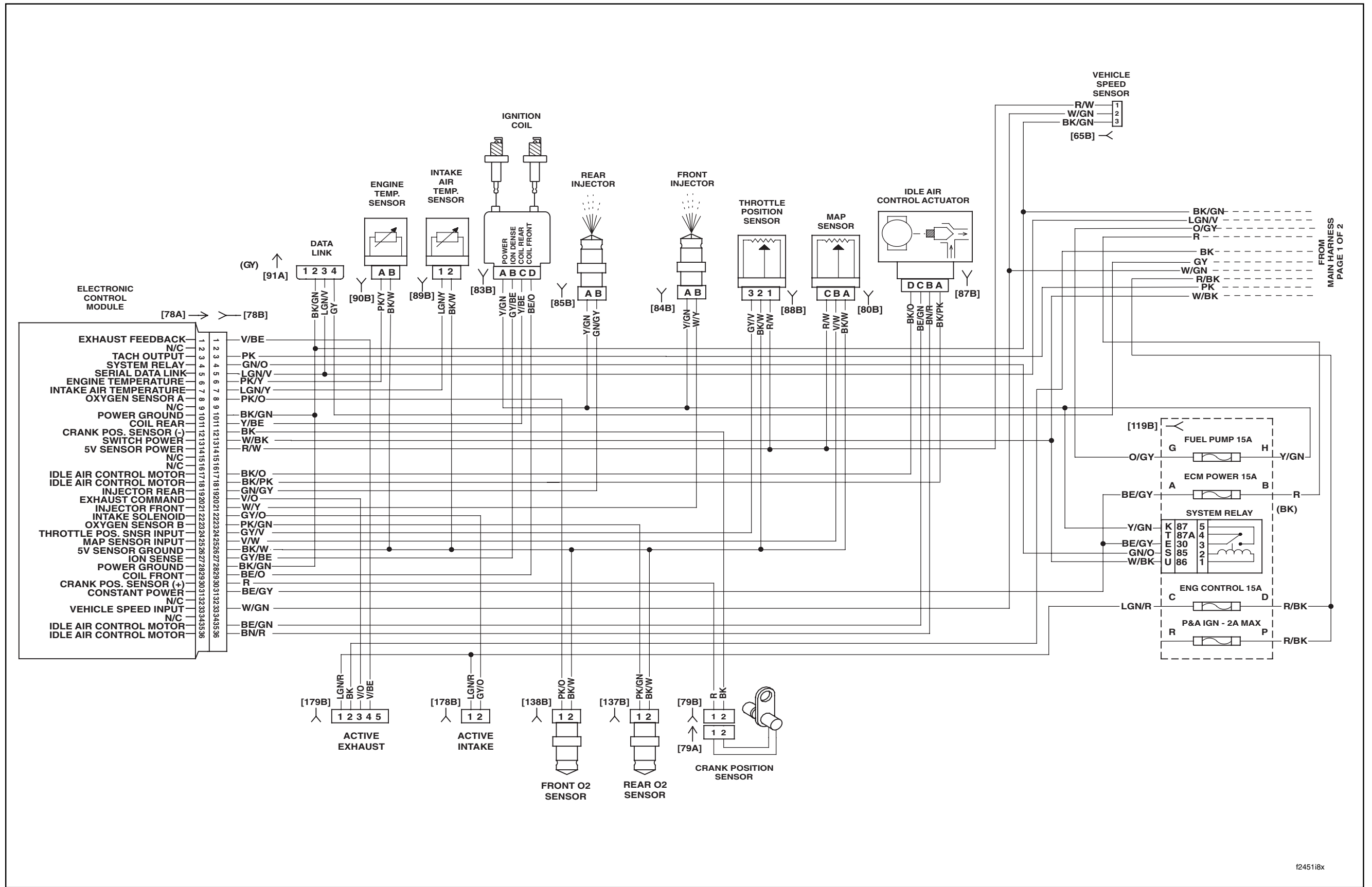

2007 FLHR, FLHRC and FLHRS, DOMESTIC and INTERNATIONAL Models, Main Harness (Page 2 of 2)

t245118x

**2007 FLHR, FLHRC and FLHRS,
DOMESTIC and INTERNATIONAL Models,
Main Harness (Page 2 of 2)**

**2007 FLHR, FLHRC and FLHRS,
DOMESTIC and INTERNATIONAL Models,
Main Harness (Page 2 of 2)**

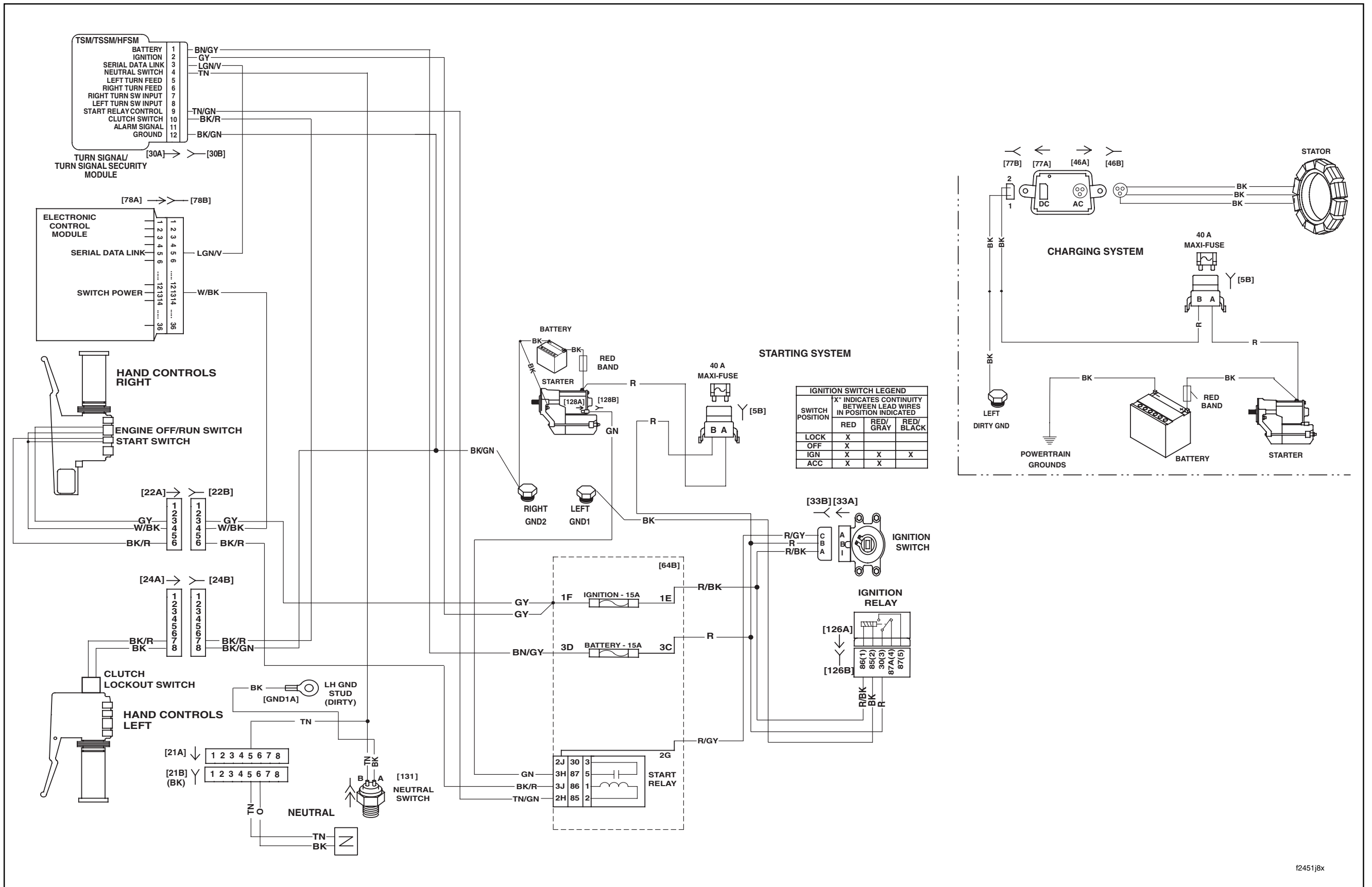

2007 FLHR, FLHRC and FLHRS, DOMESTIC and INTERNATIONAL Models, Starting and Charging

**2007 FLHR, FLHRC and FLHRS,
DOMESTIC and INTERNATIONAL Models,
Starting and Charging**

**2007 FLHR, FLHRC and FLHRS,
DOMESTIC and INTERNATIONAL Models,
Starting and Charging**

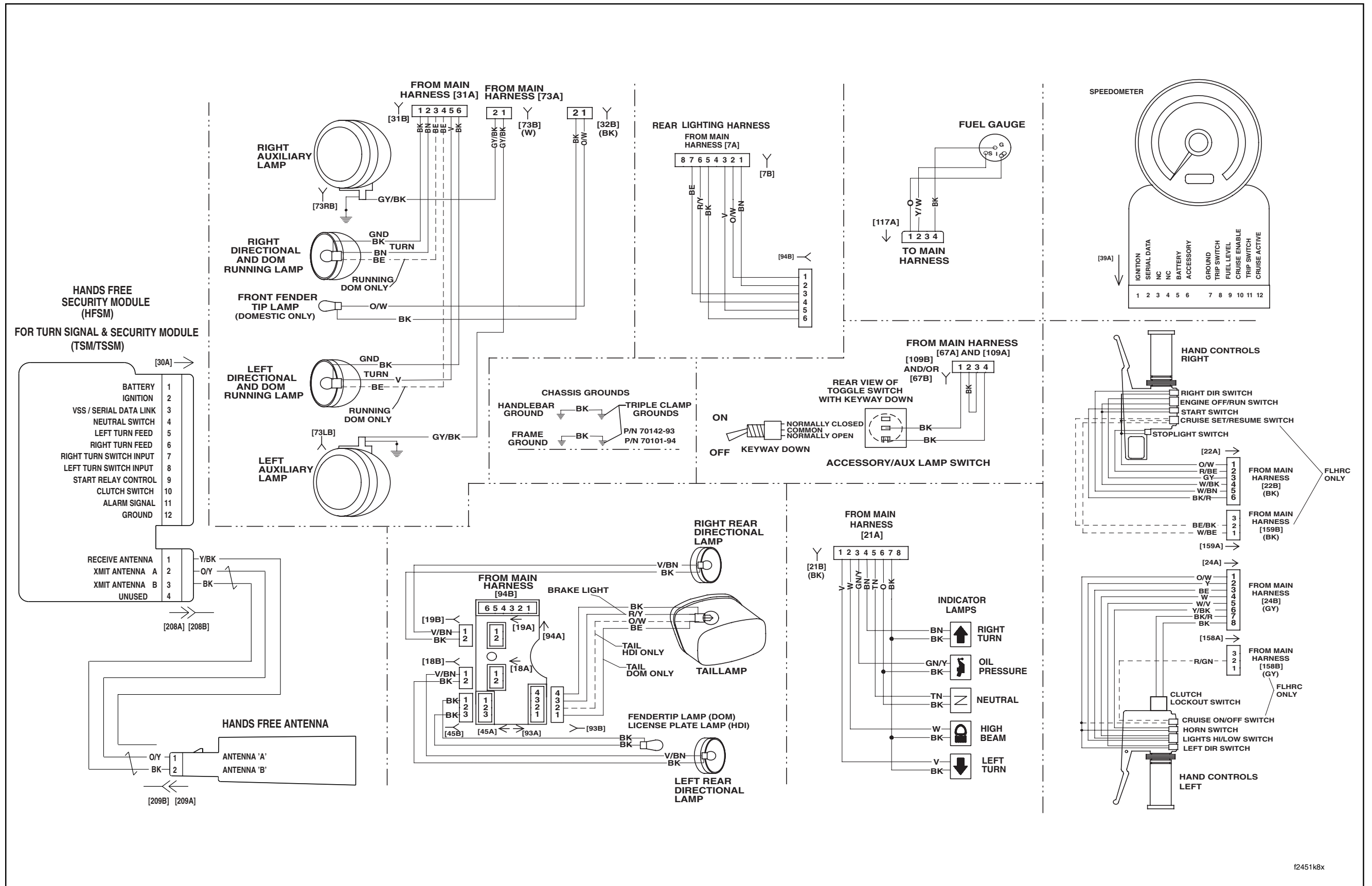

2007 FLHR, FLHRC and FLHRS, DOMESTIC and INTERNATIONAL Models, Handlebar Switches, Speedometer, Indicator Lamps, Tail Lamp, Auxiliary Lamps, Directional Lamps, Fender Tip Lamps and Aux Lamp/Accessory Switches B-65

**2007 FLHR, FLHRC and FLHRS,
DOMESTIC and INTERNATIONAL Models,
Handlebar Switches, Speedometer, Indicator Lamps,
Tail Lamp, Auxiliary Lamps, Directional Lamps,
Fender Tip Lamps, Aux Lamp/Accessory Switches
and HFSM/Antenna**

**2007 FLHR, FLHRC and FLHRS,
DOMESTIC and INTERNATIONAL Models,
Handlebar Switches, Speedometer, Indicator Lamps,
Tail Lamp, Auxiliary Lamps, Directional Lamps,
Fender Tip Lamps, Aux Lamp/Accessory Switches
and HFSM/Antenna**

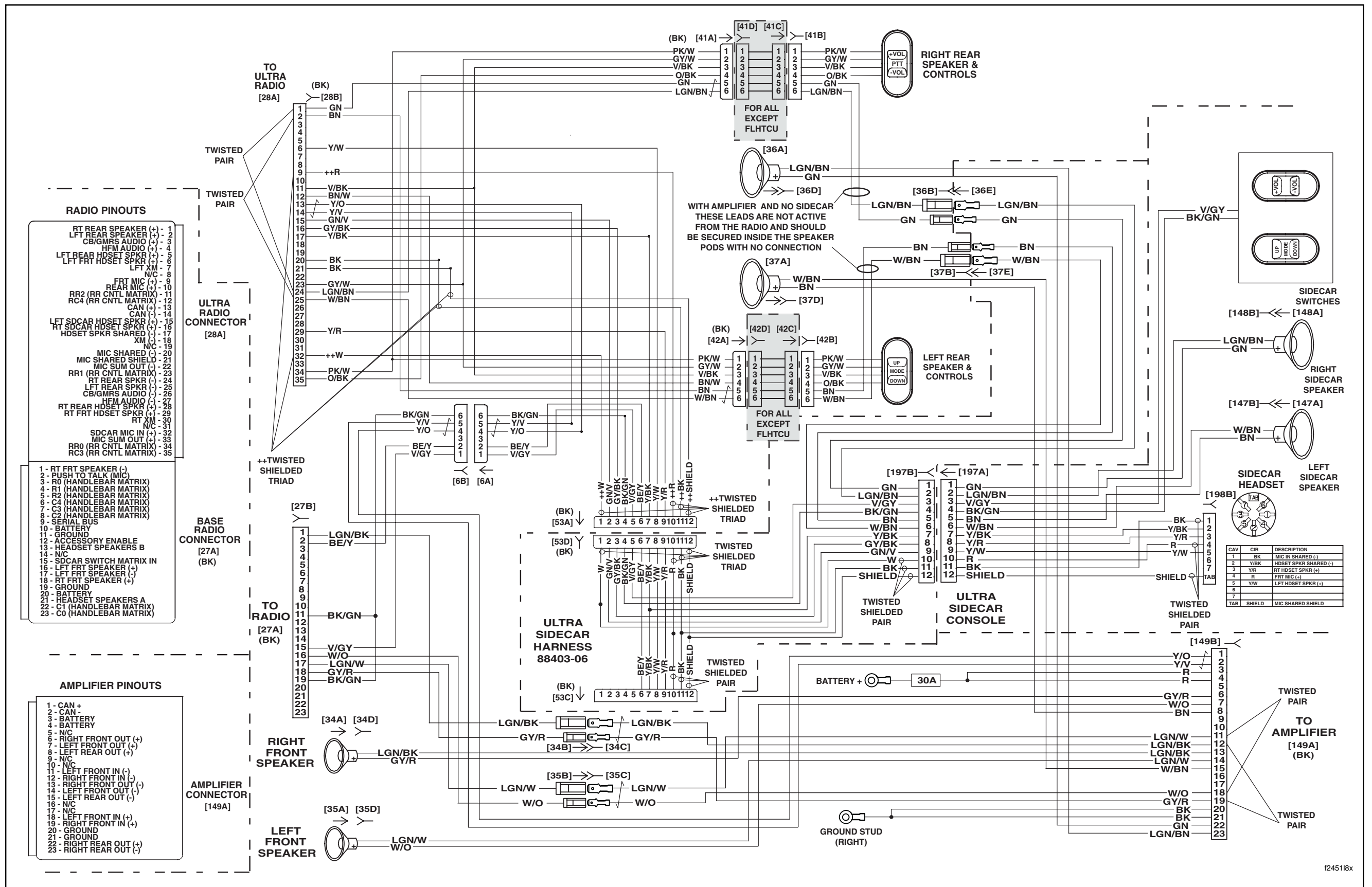

2007 TLE, TLE-U SIDECARS, DOMESTIC AND INTERNATIONAL Models, Amplifier, Sidecar Speakers and Switches

**2007 TLE, TLE-U SIDECARS,
DOMESTIC and INTERNATIONAL Models,
Amplifier, Sidecar Speakers and Switches**

**2007 TLE, TLE-U SIDECARS,
DOMESTIC and INTERNATIONAL Models,
Amplifier, Sidecar Speakers and Switches**