

GSX-R600

OWNER'S MANUAL

 **SUZUKI**

This manual should be considered a permanent part of the motorcycle and should remain with the motorcycle when resold or otherwise transferred to a new owner or operator. The manual contains important safety information and instructions which should be read carefully before operating the motorcycle.

IMPORTANT

BREAK-IN (RUNNING-IN) INFORMATION FOR YOUR MOTORCYCLE

The first 1600 km (1000 miles) are the most important in the life of your motorcycle. Proper break-in operation during this time will help ensure maximum life and performance from your new motorcycle. Suzuki parts are manufactured of high quality materials, and machined parts are finished to close tolerances. Proper break-in operation allows the machined surfaces to polish each other and mate smoothly.

Motorcycle reliability and performance depend on special care and restraint exercised during the break-in period. It is especially important that you avoid operating the engine in a manner which could expose the engine parts to excessive heat.

Please refer to the BREAK-IN (RUNNING-IN) section for specific break-in recommendations.

WARNING/CAUTION/NOTE

Please read this manual and follow its instructions carefully. To emphasize special information the words WARNING, CAUTION and NOTE carry special meanings and should be carefully reviewed.

▲ WARNING

The personal safety of the rider may be involved. Disregarding this information could result in injury to the rider.

CAUTION

These instructions point out special service procedures or precautions that must be followed to avoid damaging the machine.

NOTE: This provides special information to make maintenance easier or important instructions clearer.

FOREWORD

Motorcycling is one of the most exhilarating sports and to ensure your riding enjoyment, you should become thoroughly familiar with the information presented in this Owner's Manual before riding the motorcycle.

The proper care and maintenance that your motorcycle requires is outlined in this manual. By following these instructions explicitly you will ensure a long trouble free operating life for your motorcycle. Your authorized Suzuki dealer has experienced technicians that are trained to provide your machine with the best possible service with the right tools and equipment.

All information, illustrations, photographs and specifications contained in this manual are based on the latest product information available at the time of publication. Due to improvements or other changes, there may be some discrepancies in this manual. Suzuki reserves the right to make changes at any time.

Please note that this manual applies to all specifications or all respective destinations and explains all equipment. Therefore, your model may have different standard features than shown in this manual

SUZUKI MOTOR CORPORATION

© COPYRIGHT SUZUKI MOTOR CORPORATION 2003

TABLE OF CONTENTS

CONSUMER INFORMATION	4
ACCESSORY INSTALLATION AND PRECAUTION SAFETY TIPS	4
SAFE RIDING RECOMMENDATION FOR MOTORCYCLE RIDERS	6
SERIAL NUMBER LOCATION	7
LOCATION OF PARTS	8
CONTROLS	11
KEY	11
IGNITION SWITCH	11
INSTRUMENT PANEL	13
LEFT HANDLEBAR	20
RIGHT HANDLEBAR	21
FUEL TANK CAP	23
GEARSHIFT LEVER	24
REAR BRAKE PEDAL	24
SEAT LOCK AND HELMET HOLDERS	25
SIDE STAND	27
SUSPENSION ADJUSTMENT	28
FUEL, ENGINE OIL AND COOLANT RECOMMENDATION	31
FUEL	31
ENGINE OIL	32
COOLANT	32
BREAK-IN (RUNNING-IN)	33
MAXIMUM ENGINE SPEED RECOMMENDATION	33
VARY THE ENGINE SPEED	33
BREAKING IN THE NEW TIRES	34
AVOID CONSTANT LOW SPEED	34
ALLOW THE ENGINE OIL TO CIRCULATE BEFORE RIDING	34
OBSERVE YOUR FIRST AND MOST CRITICAL SERVICE	34
INSPECTION BEFORE RIDING	35
RIDING TIPS	36
STARTING THE ENGINE	36
STARTING OFF	37

USING THE TRANSMISSION	38
RIDING ON HILLS	39
STOPPING AND PARKING	39
INSPECTION AND MAINTENANCE	40
MAINTENANCE SCHEDULE	40
TOOLS	43
STEERING DAMPER MAINTENANCE	43
LUBRICATION POINTS	44
BATTERY	45
AIR CLEANER	46
SPARK PLUGS	48
FUEL HOSE	51
ENGINE OIL	52
IDLE SPEED	56
THROTTLE CABLE PLAY	57
CLUTCH	58
COOLANT	59
DRIVE CHAIN	60
BRAKES	63
TIRES	66
SIDE STAND/IGNITION INTERLOCK SWITCH	69
FRONT WHEEL REMOVAL	70
REAR WHEEL REMOVAL	72
LIGHT BULB REPLACEMENT	74
FUSES	76
TROUBLESHOOTING	77
MOTORCYCLE CLEANING	78
STORAGE PROCEDURE	80
SPECIFICATIONS	82



CONSUMER INFORMATION

ACCESSORY INSTALLATION AND PRECAUTION SAFETY TIPS

There are a great variety of accessories available to Suzuki owners. Suzuki can not have direct control over the quality or suitability of accessories you may wish to purchase. The addition of unsuitable accessories can lead to unsafe operating conditions. It is not possible for Suzuki to test each accessory on the market or combinations of all the available accessories; however, your dealer can assist you in selecting quality accessories and installing them correctly.

Use extreme caution when selecting and installing the accessories for your Suzuki. We have developed some general guidelines which will aid you when deciding whether, and how to equip your motorcycle.

⚠ WARNING

Improper accessories or modifications can make your motorcycle unsafe and can lead to an accident.

Never modify the motorcycle with improper or poorly installed accessories. Follow all instructions in this owner's manual regarding accessories and modifications. Use genuine SUZUKI accessories or equivalent designed and tested for your motorcycle. Consult your SUZUKI dealer if you have any questions.

- Never exceed the G.V.W. (Gross Vehicle Weight) of this motorcycle. The G.V.W. is the combined weight of the machine, accessories, payload and rider. When selecting your accessories, keep in mind the weight of the rider as well as the weight of the accessories. The additional weight of the accessories may not only create an unsafe riding condition but may also affect the riding stability.

G.V.W.: 380 kg (840 lbs)

at the tire pressure (cold)

Front: 2.50 kgf/cm² (36 psi)

Rear: 2.50 kgf/cm² (36 psi)

- Anytime that additional weight or aerodynamic affecting accessories are installed, they should be mounted as low as possible, as close to the motorcycle and as near the center of gravity as is feasible. The mounting brackets and other attachment hardware should be carefully checked to ensure that it provides for a rigid, non-movable mount. Weak mounts can allow the shifting of the weight and create a dangerous, unstable condition.
- Inspect for proper ground clearance and bank angle. An improperly mounted load could critically reduce these two safety factors. Also determine that the "load" does not interfere with the operation of the suspension, steering or other control operations.

- Accessories fitted to the handlebars or the front fork area can create serious stability problems. This extra weight will cause the motorcycle to be less responsive to your steering control. The weight may also cause oscillations in the front end and lead to instability problems. Accessories added to the handlebar or front fork should be as light as possible and kept to a minimum.

- The motorcycle may be affected by a lifting condition or by an instability in cross winds or when being passed or passing large vehicles. Improperly mounted or poorly designed accessories can result in an unsafe riding condition, therefore caution should be used when selecting and installing all accessories.

- Certain accessories displace the rider from his or her normal riding position. This limits the freedom of movement of the rider and may limit his or her control ability.
- Additional electrical accessories may overload the existing electrical system. Severe overloads may damage the wiring harness or create a dangerous situation due to the loss of electrical power during the operation of the motorcycle.

When carrying a load on the motorcycle, mount it as low as possible and as close as possible to the machine. An improperly mounted load can create a high center of gravity which is very hazardous and makes the motorcycle difficult to handle. The size of the "load" can also affect the aerodynamics and handling of the motorcycle. Balance the load between the right and left side of the motorcycle and fasten it securely.

⚠ WARNING

Placing objects in the space behind the fairing can interfere with steering and can lose control.

Do not carry any objects in the space behind the fairing.

MODIFICATION

Modification of the motorcycle, or removal of original equipment may render the vehicle unsafe or illegal.

The frame of this motorcycle is made of an aluminium alloy. Therefore, never make any modifications such as drilling or welding to the frame as it weakens the strength of the frame significantly. Failure to heed this warning could result in an unsafe vehicle operating condition and subsequent accident. Suzuki will not be responsible in any way for personal injury or damage to the motorcycle caused by frame modifications. Bolt on accessories that do not modify the frame in any way may be installed provided that the GVW is not exceeded. For the GVW, refer to the **ACCESSORY INSTALLATION AND PRECAUTION SAFETY TIPS** section of this owner's manual.

⚠ WARNING

Modification to an aluminum alloy frame, such as drilling or welding, weakens the frame. This could result in an unsafe operating condition and may lead to an accident.

Never make any modifications to the frame.

SAFE RIDING RECOMMENDATION FOR MOTORCYCLE RIDERS

Motorcycle riding is great fun and an exciting sport. Motorcycle riding also requires that some extra precautions be taken to ensure the safety of the rider and passenger. These precautions are:

WEAR A HELMET

Motorcycle safety equipment starts with a quality helmet. One of the most serious injuries that can happen is a head injury. **ALWAYS** wear a properly approved helmet. You should also wear suitable eye protection.

RIDING APPAREL

Loose, fancy clothing can be uncomfortable and unsafe when riding your motorcycle. Choose good quality motorcycle riding apparel when riding your motorcycle.

INSPECTION BEFORE RIDING

Review thoroughly the instructions in the "INSPECTION BEFORE RIDING" section of this manual. Do not forget to perform an entire safety inspection to ensure the safety of the rider and its passenger.

FAMILIARIZE YOURSELF WITH THE MOTORCYCLE

Your riding skill and your mechanical knowledge form the foundation for safe riding practices. We suggest that you practice riding your motorcycle in a non-traffic situation until you are thoroughly familiar with your machine and its controls. Remember practice makes perfect.

KNOW YOUR LIMITS

Ride within the boundaries of your own skill at all times. Knowing these limits and staying within them will help you to avoid accidents.

BE EXTRA SAFETY CONSCIOUS ON BAD WEATHER DAYS

Riding on bad weather days, especially wet ones, requires extra caution. Braking distances double on a rainy day. Stay off the painted surface marks, manhole covers and greasy appearing areas as they can be especially slippery. Use extreme caution at railway crossings and on metal gratings and bridges. Whenever in doubt about road condition, slow down!

RIDE DEFENSIVELY

The most common type of motorcycle accident occurs when a car traveling towards a motorcycle turns round corner in front of the motorcyclist. Ride defensively. Wise motorcyclist uses a strategy of assuming they are invisible to other drivers, even in broad daylight. Wear bright, reflecting clothing. Turn on the headlight and taillight every time even on a bright, sunny day to attract driver's attention. Do not ride in another driver's blind spot.

SERIAL NUMBER LOCATION

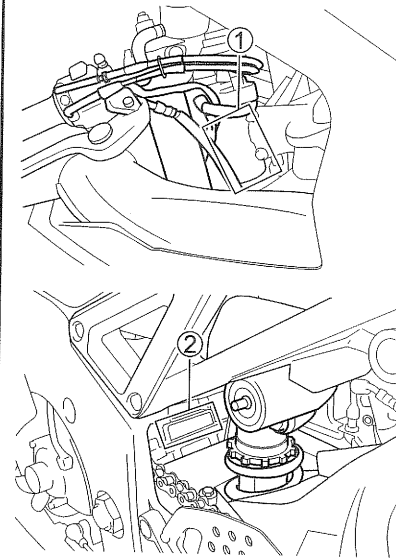

The frame and/or engine serial numbers are used to register the motorcycle. They are also used to assist your dealer when ordering parts or referring to special service information. The frame number ① is stamped on the steering head tube. The engine serial number ② is stamped on the crankcase assembly.

Please write down the numbers in the box provided below for your future reference.

Frame number:

Engine number:

LOCATION OF PARTS

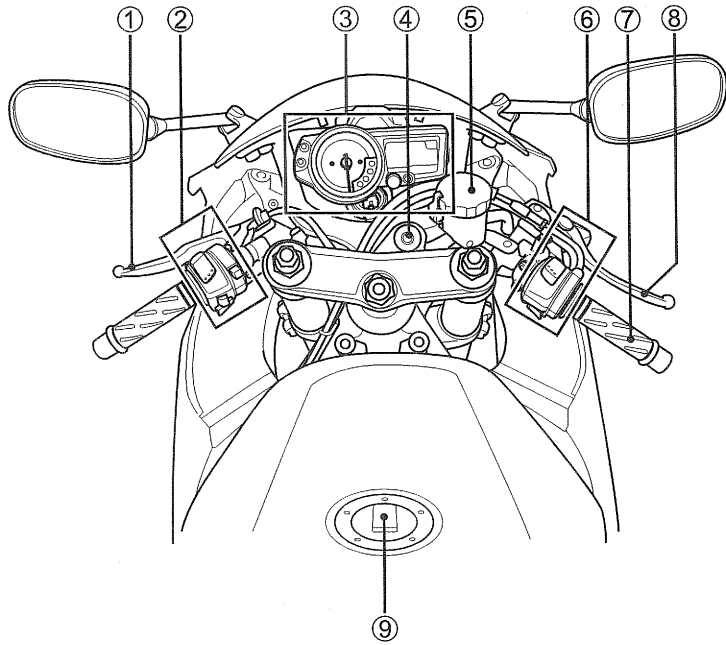

- ① Clutch lever
- ② Left handlebar switches
- ③ Instrument panel
- ④ Ignition switch
- ⑤ Front brake fluid reservoir
- ⑥ Right handlebar switches
- ⑦ Throttle grip
- ⑧ Front brake lever
- ⑨ Fuel tank cap

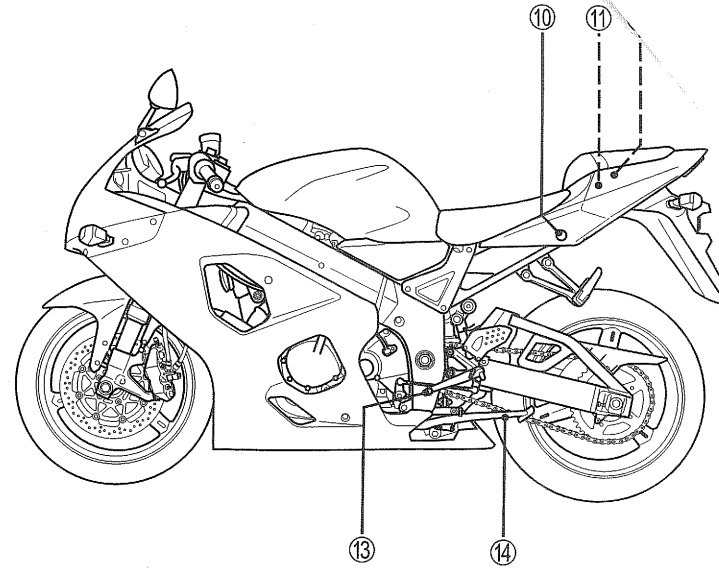

- ⑩ Seat lock
- ⑪ Tools
- ⑫ Helmet holders
- ⑬ Gearshift lever
- ⑭ Side stand

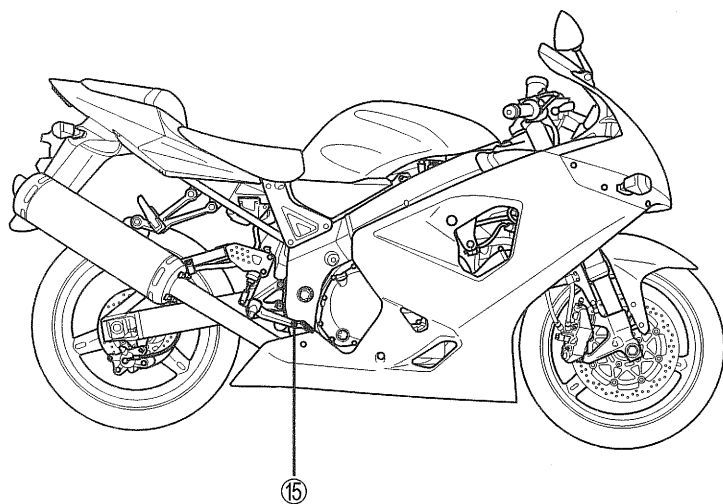

⑮ Rear brake pedal

CONTROLS

KEY

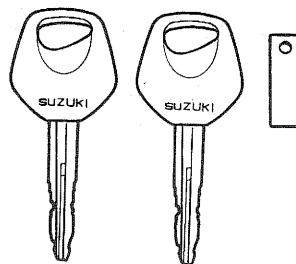

This motorcycle comes equipped with a main ignition key and a spare one. Keep the spare key in a safe place.

The key number is stamped on a plate provided with the keys. This number is used when making replacement keys. Please write your key number in the box provided for your future reference.

Key number:

IGNITION SWITCH

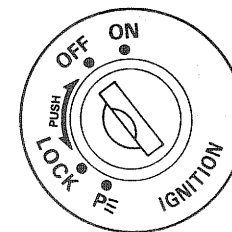

The ignition switch has four positions:

“OFF” POSITION

All electrical circuits are cut off. The engine will not start. The key can be removed.

“ON” POSITION

The ignition circuit is completed and the engine can now be started. The headlight and taillight will automatically be turned on when the key is in this position. The key cannot be removed from the ignition switch in this position.

NOTE: Start the engine promptly after turning the key to the “ON” position, or the battery will lose power due to consumption by the headlight and taillight.

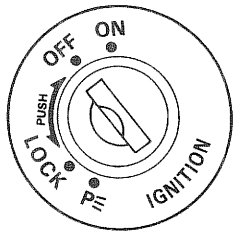

“LOCK” POSITION

To lock the steering, turn the handlebar all the way to the left. Push down and turn the key to the “LOCK” position and remove the key. All electrical circuits are cut off.

“P” (Parking) POSITION

When parking the motorcycle, lock the steering and turn the key to the “P” position. The key can now be removed and the *position light and taillight will remain lit and the steering will be locked. This position is for night time roadside parking to increase visibility.

* Canadian model does not have position light.

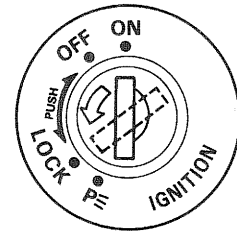

Turn the ignition switch to “LOCK” position and change the lid hole position when leaving your motorcycle.

⚠ WARNING

Turning the ignition switch to the “P” (PARKING) or “LOCK” position while the motorcycle is moving can be hazardous. Moving the motorcycle while the steering is locked can be hazardous. You could lose your balance and fall, or you could drop the motorcycle.

Stop the motorcycle and place it on the side stand before locking the steering. Never attempt to move the motorcycle when the steering is locked.

NOTE: The key hole can be covered by turning the lid for anti-theft purpose.

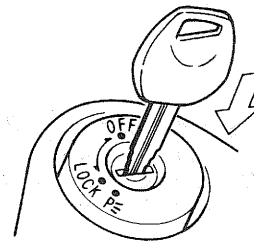
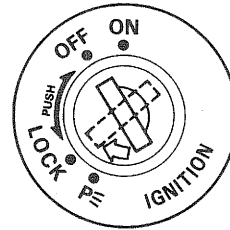
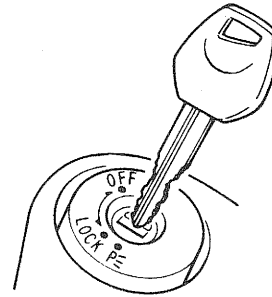

Align the lid hole position to the key hole position when inserting the key.

INSTRUMENT PANEL

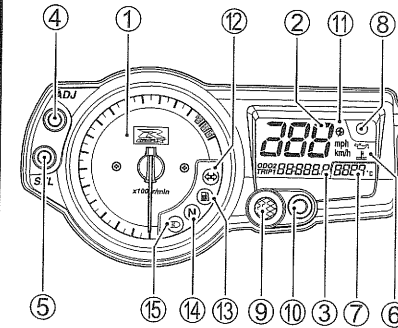

The fuel indicator light ⑬, LCD's and tachometer meter needle work as follows to confirm their function when the ignition switch is turned to the “ON” position.

- The fuel indicator light ⑬ comes on for 3 seconds.
- All LCD segments display for 3 seconds.
- Tachometer needle moves to the full scale and returns to the home position.

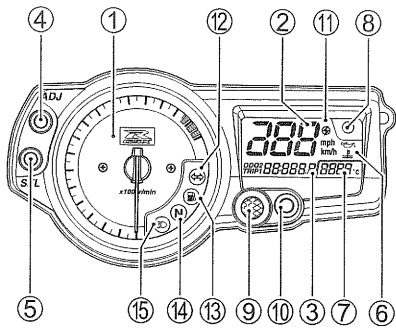

TACHOMETER ①

The tachometer indicates the engine speed in revolutions per minute (r/min).

SPEEDOMETER ②

The speedometer indicates the road speed in miles per hour and/or kilometers per hour.

CLOCK/ODOMETER/TRIP METER ③

The display has four functions, clock, odometer and two trip meters. When the ignition switch is turned to the "ON" position, the display indicates the test pattern shown below for three seconds.



To change the display, push the button ⑤. The display changes in the order below.

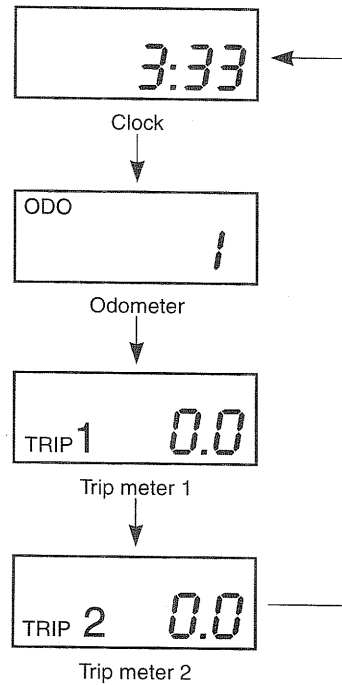

NOTE: Set the meter to odometer, then press and hold buttons, ④ and ⑤, for 2 seconds to change between km/h and mph. (UK only)

Clock

The clock indicates 12-hour mode. Follow the procedure below to adjust the clock.

1. Display clock. Push the buttons, ④ and ⑤, simultaneously for more than 2 seconds until the hour display blinks.
2. Adjust the hour display by pushing the button ④.

NOTE: When the button ④ is held in the display advances continuously.

3. Push the button ⑤ to highlight the minute display.
4. Adjust the minute display by pushing the button ④.
5. Push the button ⑤ to resume clock mode.

Odometer

The odometer registers the total distance that the motorcycle has been ridden.

Trip meters

The two trip meters are resettable odometers. They can register two kinds of distances at the same time. For instance, trip meter 1 can register the trip distance and trip meter 2 can register the distance between fuel stops.

To reset the a meter to zero, push the button ④ for two seconds while the display indicates the trip meter 1, or 2, you want to reset.

⚠ WARNING

Operating the display while riding can be hazardous. Removing a hand from the handlebars can reduce your ability to control the motorcycle.

Always keep both hands on the handlebars during riding.

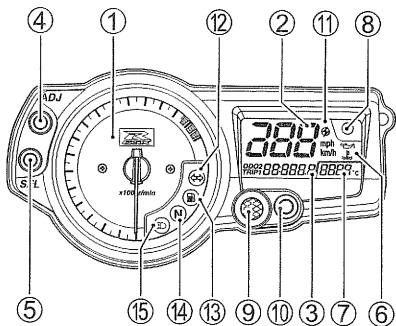

COOLANT TEMPERATURE METER/OIL PRESSURE INDICATOR/FUEL INJECTION SYSTEM INDICATOR ⑥, ⑦

The display and the indicator light ⑧ in the LCD have three functions, coolant temperature indicator, oil pressure indicator and fuel injection system indicator. The display ⑦ normally indicates coolant temperature. The oil pressure symbol activates when the oil pressure is low.

Coolant Temperature Meter

When the ignition switch is turned to the "ON" position, the display indicates the test pattern shown below for three seconds. Then the display changes to the coolant temperature meter. While the coolant temperature is below 20 °C, the display does not indicate a number but indicates "— — —".

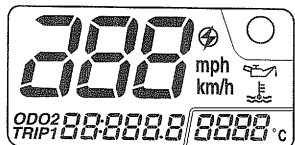

When the coolant temperature is higher than 120 °C, the display flickers and the indicator light ⑧ comes on. Further, if the temperature exceeds 140 °C, the display blinks "HI" and the indicator light ⑧ remains on.

CAUTION

Running the engine with high engine coolant temperature can cause serious engine damage. If the engine coolant temperature indicates more than 120 °C and indicator light comes on, stop the engine to let it cool.

Do not run the engine until the coolant temperature indicates less 120 °C or below.

Oil Pressure Indicator

With the ignition switch in the "ON" position but the engine not started, the symbol "⚡" in the display and the indicator light ⑧ comes on. As soon as the engine is started, the symbol "⚡" and the indicator light should go out.

When the engine oil pressure drops under the normal operating range, the symbol "⚡" in the display and the indicator light ⑧ come on.

CAUTION

Riding the motorcycle with the symbol "⚡" and the indicator light lit can damage the engine and transmission.

Whenever the symbol "⚡" and the indicator lights up, indicating low oil pressure, stop the engine immediately. Check the oil level and make sure the proper amount of oil is in the engine. If the light still does not go out, have your authorized Suzuki dealer or qualified mechanic troubleshoot your motorcycle.

Fuel Injection System Indicator



If the fuel injection system fails, the red indicator light ⑧ comes on and the display indicates "FI" in the following two modes;

- A. The display indicates "FI" and the coolant temperature alternately, and the red indicator light ⑧ comes on and remains lit.
- B. The display indicates "FI" continuously and the red indicator light ⑧ blinks while cranking the engine.

The engine may continue to run in mode A, but the engine will not run in mode B.

CAUTION

Riding the motorcycle with the display indicating the problem with the fuel injection system and with the indicator light lit can damage the engine.

Whenever the red indicator light is lit and the display indicates "FI", have your authorized Suzuki dealer or qualified mechanic inspect the fuel injection system as soon as possible.

NOTE:

- If the display indicates "FI" and the coolant temperature alternately, and the red indicator light comes on and remains lit, keep the engine running and bring your motorcycle to an authorized Suzuki dealer. If the engine stalls, try restarting the engine after turning the ignition switch off and on.
- If the display indicates "FI" continuously and the red indicator light blinks, the engine will not start.



When the display indicates "CHECK", check following items;

- Make sure that the engine stop switch is in the "O" position.
- Make sure that the transmission is in neutral or the side stand is fully up.

If the display still indicates "CHECK" after above procedure, inspect the ignition fuse and connection of lead wire couplers.

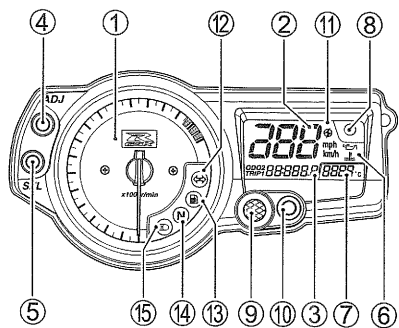

ENGINE RPM INDICATOR LIGHT ⑨

The engine rpm indicator light comes on when the engine speed becomes preset engine rpm. Turn the ignition switch to the "ON" position and push the button ⑩ more than 2 seconds to use the engine rpm indicator. The indicator light comes on for 2 seconds and "⚡" ⑪ comes on in the instrument panel. Push the button less than 2 seconds to cancel the indicator. The indicator light blinks 3 times and indicator "⚡" goes off. The indicator is cancelled when the ignition switch is turned off.

The preset engine rpm can be adjusted from 7000 r/min to 15500 r/min step 500 r/min. To adjust the engine rpm indicator:

1. Push the button first and turn the ignition switch to the "ON" position.
2. The tachometer needle indicates preset engine rpm and indicator light comes on.
3. Push the button to change the preset engine rpm.
4. Push the button for 2 seconds to resume to operation mode. The indicator light goes off and "⚡" comes on.

NOTE: Preset adjustment mode will be cancelled when the ignition switch is turned to the "OFF" position or the motorcycle speed is increased more than 10 km/h (7 mph). Push the button more than 2 seconds to fix the adjusted preset rpm. The tachometer indicates 0 r/min, indicator light goes off and the instrument panel indicates "⚡".

TURN SIGNAL INDICATOR LIGHT ⑫

When the turn signals are being operated either to the right or to the left, the indicator will flash at the same time.

NOTE: If turn signal light is not operating properly due to bulb filament or circuit failure, the indicator light flickers more quickly to notify the rider of the existence of trouble.

FUEL INDICATOR LIGHT ⑬

When the fuel in the fuel tank drops below approximately 1.7 liters (1.8/1.5 US/imp. qt), this indicator light comes on. This indicator light comes on for three seconds when the ignition switch is turned to the "ON" position, then the indicator light should go out if there is enough fuel in the tank.

NOTE: When the fuel indicator light comes on, you should add fuel to the fuel tank at the first opportunity to avoid running out of fuel.

NEUTRAL INDICATOR LIGHT ⑭

The green light will come on when the transmission is in neutral. The light will go out when you shift into any gear other than neutral.

HIGH BEAM INDICATOR LIGHT ⑮

The blue indicator light will be lit when the headlight high beam is turned on.

LEFT HANDLEBAR

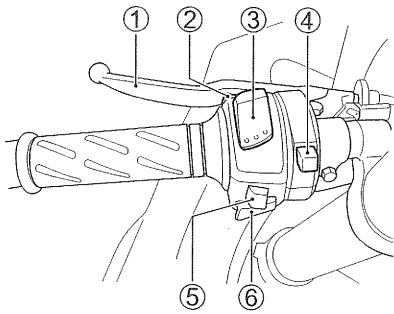

CLUTCH LEVER ①

The clutch lever is used for disengaging the drive to the rear wheel when starting the engine or shifting the transmission gear. Squeezing the lever disengages the clutch.

HEADLIGHT FLASHER SWITCH ②

Press the switch to light the headlight high beam. The headlight high beam will be lit when the dimmer switch is in "LO" position.

DIMMER SWITCH ③

"LO" position

The headlight low beam and taillight turn on.

"HI" position

The headlight high beam and taillight turn on. The high beam indicator light also turns on.

HAZARD WARNING SWITCH ④

All four turn signal lights and indicators will flash simultaneously when the switch is turned on with the ignition switch in "ON" or "P" position. Use the hazard warning lights to warn other traffic during emergency parking or when your vehicle could otherwise become a traffic hazard.

TURN SIGNAL LIGHT SWITCH ⑤

Moving the switch to the "←" position will flash the left turn signals. Moving the switch to the "→" position will flash the right turn signals. The indicator light will also flash intermittently. To cancel turn signal operation, push the switch in.

⚠ WARNING

Failure to use the turn signals, and failure to turn off the turn signals can be hazardous. Other drivers may misjudge your course and this may result in an accident.

Always use the turn signals when you intend to change lanes or make a turn. Be sure to turn off the turn signals after completing the turn or lane change.

HORN SWITCH "H" ⑥

Press the switch to sound the horn.

RIGHT HANDLEBAR

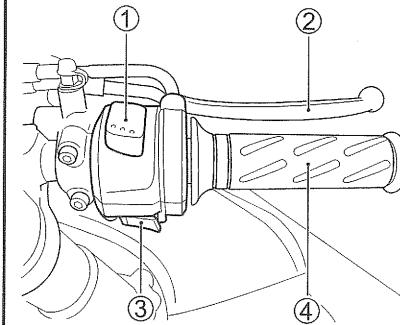

ENGINE STOP SWITCH ①

"OFF" position

The ignition circuit is off. The engine cannot start or run.

"ON" position

The ignition circuit is on and the engine can run.

CAUTION

To prevent electrical system damage, do not operate the starter motor more than five seconds at a time.

If the engine does not start after several attempts, check the fuel supply and ignition system. Refer to the TROUBLESHOOTING section in this manual.

FRONT BRAKE LEVER ②

The front brake is applied by squeezing the brake lever gently toward the throttle grip. This motorcycle is equipped with a disk brake system and excessive pressure is not required to slow the machine down properly. The brake light will be lit when the lever is squeezed inward.

Front Brake Lever Adjustment

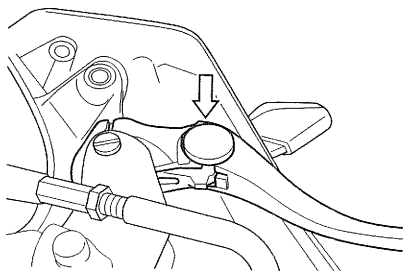

The distance between the throttle grip and the front brake lever is adjustable among six positions. To change the position, push the brake lever forward and turn the adjuster to the desired position. When changing the brake lever position, always be sure the adjuster stops in the proper position; a projection of the brake lever holder should fit into the depression of the adjuster. This motorcycle is delivered from the factory with its adjuster set on position 3.

⚠ WARNING

Adjusting the front brake lever position while riding can be hazardous. Removing a hand from the handlebars can reduce your ability to control the motorcycle.

Always keep both hands on the handlebars while riding.

22

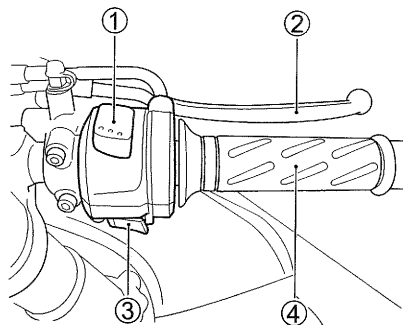

ELECTRIC STARTER BUTTON “③”

This button is used for operating the starter motor. With the ignition switch in the “ON” position, the engine stop switch in “O” and the transmission in neutral, push the electric starter button to operate the starter motor and start the engine.

NOTE: This motorcycle is equipped with interlock switches for the ignition circuit and the starter circuit. The engine can only be started if:

- The transmission is in neutral and the clutch is disengaged, or
- The transmission is in gear, the side stand is fully up and the clutch is disengaged.

THROTTLE GRIP ④

Engine speed is controlled by the position of the throttle grip. Twist it toward you to increase engine speed. Turn it away from you to decrease the engine speed.

FUEL TANK CAP

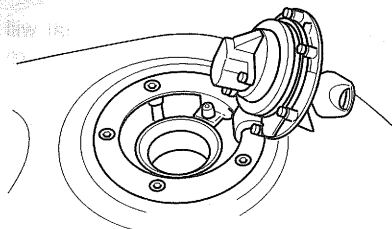
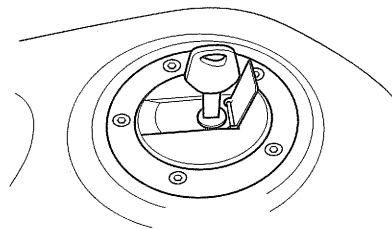

To open the fuel tank cap, insert the ignition key into the lock and turn it clockwise. With the key inserted, lift up with the key and open the fuel tank cap. To close the fuel tank cap, push the cap down firmly with the key in the cap lock.

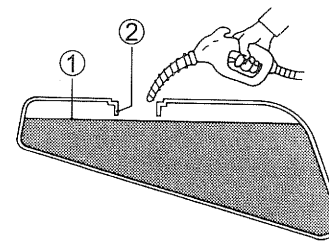

- ① Fuel level
- ② Filler neck

⚠ WARNING

Overfilling the fuel tank can cause the fuel to overflow when it expands due to heat from the engine or the sun. Spilled fuel can catch on fire.

Never fill the fuel above the bottom of the filler neck.

⚠ WARNING

Fuel and fuel vapor are highly flammable and toxic. You can be burned or poisoned when refueling.

- Stop the engine and keep flames, sparks and heat sources away.
- Refuel only outdoors or in a well ventilated area.
- Do not smoke.
- Wipe up spills immediately.
- Avoid breathing fuel vapor.
- Keep children and pets away.

23

GEARSHIFT LEVER

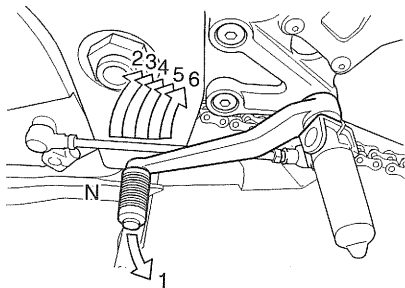

This motorcycle has a 6-speed transmission which operates as shown. To shift properly, pull the clutch lever and close the throttle at the same time you operate the gearshift lever. Lift the gearshift lever to upshift and depress the lever to downshift. Neutral is located between low and 2nd gear. When neutral is desired, depress or lift the lever halfway between low and 2nd gear.

NOTE: When the transmission is in neutral the green indicator light on the instrument panel will be lit. However, even though the light is illuminated, cautiously release the clutch lever slowly to determine whether the transmission is positively in neutral.

Reduce the motorcycle speed before down-shifting. When down-shifting, the engine speed should be increased before the clutch is engaged. This will prevent unnecessary wear on the drive train components and the rear tire.

REAR BRAKE PEDAL

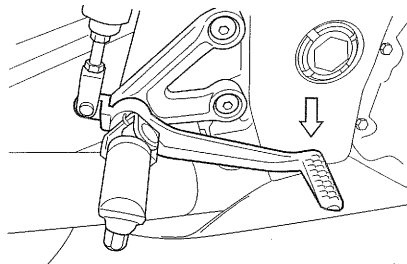

Depressing the rear brake pedal will apply the rear disk brake. The brake light will be illuminated when the rear brake is operated.

SEAT LOCK AND HELMET HOLDERS

Front Seat
To remove the front seat.

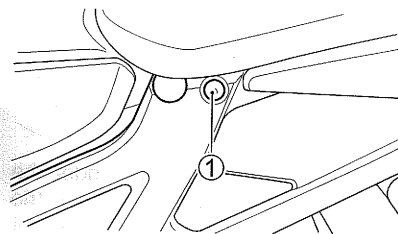

1. Remove the bolts ① (right and left).
2. Raise the front end of the seat and slide it forward.

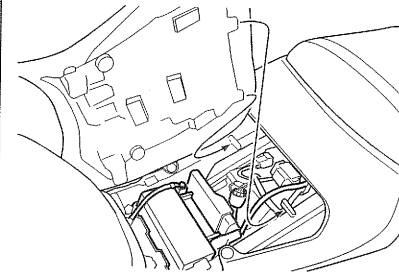

To reinstall the seat, slide the seat hooks into the seat hook retainers on the frame and tighten the bolts securely.

⚠ WARNING

Failure to install the seat properly could allow the seat to move and cause loss of rider control.

Fasten the seat securely in its proper position.

Rear Seat

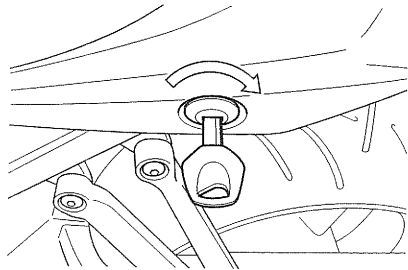

The seat lock is located under the left frame cover. To remove the rear seat, insert the ignition key into the lock and turn it clockwise. Raise the front end of the seat and slide it forward.

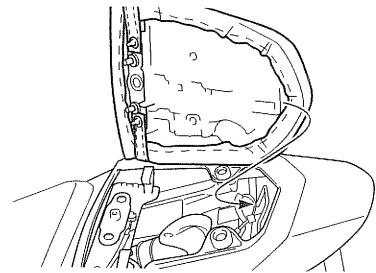

To reinstall the seat, slide the seat hooks into the seat hook retainers and push down firmly until the seat snaps into the locked position.

⚠ WARNING

Failure to install the seat properly could allow the seat to move and cause loss of rider control.

Latch the seat securely in its proper position.

A seat tail cover for solo riding can be attached by using the same procedure as the rear seat.

26

Helmet Holders

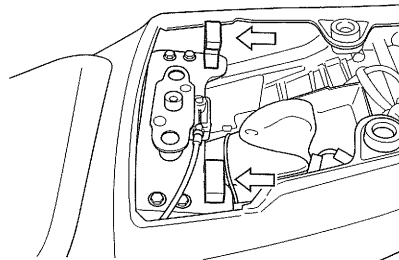

There are helmet holders under the rear seat. To use them, remove the seat, hook your helmet to the helmet holder and refit the seat.

⚠ WARNING

Riding with a helmet fastened to the helmet holder can interfere with rider control.

Never carry a helmet fastened to the helmet holder. Fix the helmet securely atop the seat if you must carry it.

SIDE STAND

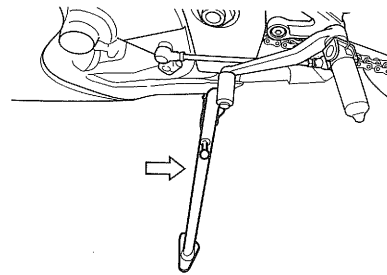

An interlock switch is provided to cut off the ignition circuit when the side stand is down and the transmission is in any gear other than neutral.

The side stand/ignition interlock switch works as follows:

- If the side stand is down and the transmission is in gear, the engine can not be started.
- If the engine is running and the transmission is shifted into gear with the side stand down, the engine will stop running.
- If the engine is running and the side stand is put down with the transmission in gear, the engine will stop running.

⚠ WARNING

Riding with the side stand incompletely retracted can result in an accident when you turn left.

- Check operation of the side stand/ignition interlock system before riding.
- Always retract the side stand completely before starting off.

CAUTION

Park the motorcycle on firm, level ground to help prevent it from falling over.

If you must park on an incline, aim the front of the motorcycle uphill and put the transmission into 1st gear to reduce the possibility of rolling off the side stand.

27

SUSPENSION ADJUSTMENT

The standard settings of both front and rear suspensions are selected to meet various riding conditions such as low to high motorcycle speed and light to heavy load on the motorcycle. The suspension settings can be adjusted for your preference and fine-tuning.

FRONT SUSPENSION Spring Pre-load Adjustment

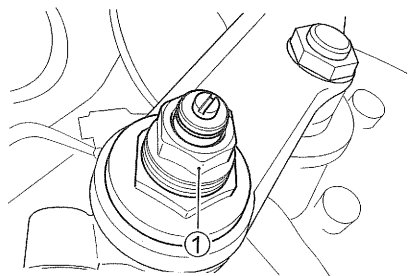

To change the spring pre-load, turn the adjuster ① clockwise or counterclockwise. Turning the adjuster clockwise will increase the spring pre-load. Turning the adjuster counterclockwise will decrease the spring pre-load. There are seven grooved lines on the side of the adjuster ① for reference. Position 7 provides the minimum spring pre-load and position 0 provides the maximum pre-load. This motorcycle is delivered from the factory with its adjuster set on position 4.

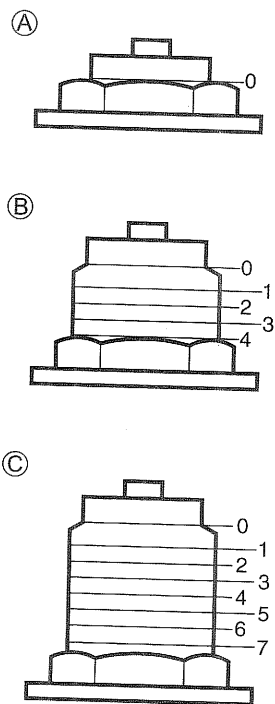

- (A) Position 0
- (B) Position 4
- (C) Position 7

Damping Force Adjustment

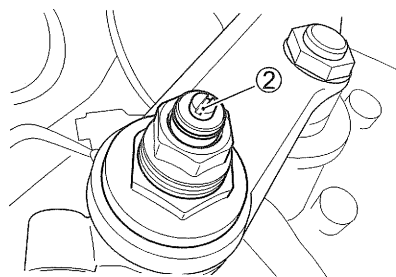

Fully turned in

1 and 3/4 turns out

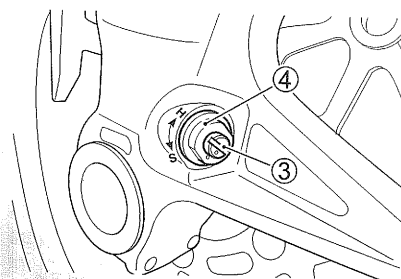

Fully turned in

1 and 3/4 turns out

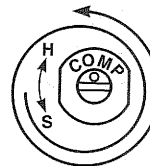

The rebound and compression damping force can be individually adjusted by turning the respective adjusters. The rebound damping force adjuster ② is located at the top of the front fork. The compression damping force adjuster ③ is located at the bottom of the front fork.

To adjust the damping force, set the adjuster to the standard setting first and then adjust the adjuster to the desired position.

To set the rebound damping force adjuster to the standard position, turn the adjuster clockwise until it stops and then turn it counterclockwise 1 and 3/4 turns until the punch mark aligns with the arrow mark.

To set the compression damping force adjuster to the standard position, turn the adjuster clockwise until it stops and then turn it counterclockwise 1 and 3/4 turns until the punch mark aligns with the arrow mark.

Turn the adjuster clockwise from the standard position to stiffen the damping force. Turn the adjuster counterclockwise to soften the damping force. The damping force should be adjusted gradually, 1/8 turn at a time, to fine-tune the suspension.

NOTE: Do not loosen the adjuster base ④, or front fork oil will ooze through the adjuster base.

⚠ WARNING

Unequal suspension adjustment can cause poor handling and loss of stability.

Adjust the right and left front forks to the same settings.

REAR SUSPENSION Spring Pre-load Adjustment

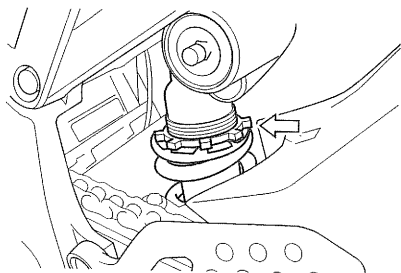

The adjustment can be performed by changing the adjuster ring position. However, Suzuki recommends that this adjustment be done by your authorized Suzuki dealer, since a special tool is needed for this job.

Damping Force Adjustment

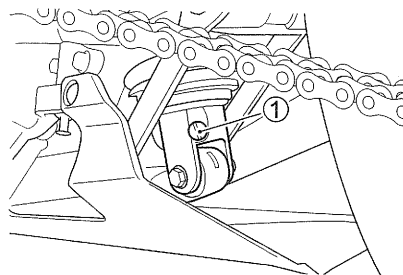

Fully turned in

2 turns out

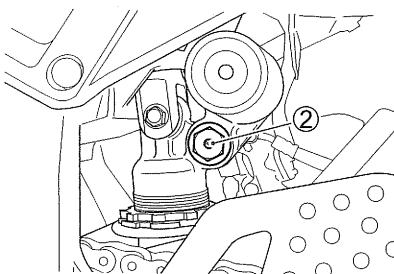
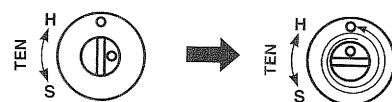

Fully turned in

1 and 3/4 turns out

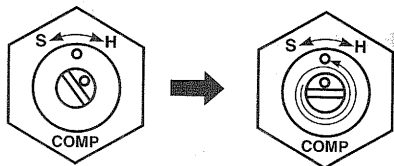

The rebound and compression damping force can be individually adjusted by turning the respective adjusters. The rebound damping force adjuster ① is located at the bottom of the rear suspension. The compression damping force adjuster ② is located at the left side of the motorcycle.

To adjust the damping force, set the adjuster to the standard setting first and then adjust the adjuster to the desired position.

To set the rebound damping force adjuster to the standard position, turn the adjuster clockwise until it stops and then turn it counterclockwise 2 turns until the two punch marks align.

To set the compression damping force adjuster to the standard position, turn the adjuster clockwise until it stops and then turn it counterclockwise 1 and 3/4 turns until the two punch marks align.

Turn the adjuster clockwise from the standard position to stiffen the damping force. Turn the adjuster counterclockwise to soften the damping force. The damping force should be adjusted gradually, 1/8 turn at a time, to fine-tune the suspension.

FUEL, ENGINE OIL AND COOLANT RECOMMENDATION

FUEL

Use unleaded gasoline with an octane rating of 91 or higher (Research method). Unleaded gasoline can extend spark plug life and exhaust components life.

(For Canada)

Your motorcycle requires unleaded gasoline with a minimum pump octane rating of 87 ((R+M)/2 method). In some areas, the only fuels that are available are oxygenated fuels. Oxygenated fuels which meet the minimum octane requirement and the requirements described below may be used in your motorcycle without jeopardizing the New Vehicle Limited Warranty or the Emission Control System Warranty.

NOTE: Oxygenated fuels are fuels which contain oxygen-carrying additives such as MTBE or alcohol.

Gasoline Containing MTBE

Unleaded gasoline containing MTBE (Methyl Tertiary Butyl Ether) may be used in your motorcycle if the MTBE content is not greater than 15%. This oxygenated fuel does not contain alcohol.

Gasoline/Ethanol Blends

Blends of unleaded gasoline and ethanol (grain alcohol), also known as GASOHOL, may be used in your motorcycle if the ethanol content is not greater than 10%.

Gasoline/Methanol Blends

Fuel containing 5 % or less methanol (wood alcohol) may be suitable for use in your motorcycle if they contain co-solvents and corrosion inhibitors.

DO NOT USE fuels containing more than 5 % methanol under any circumstances. Fuel system damage or motorcycle performance problems resulting from the use of such fuels are not the responsibility of Suzuki and may not be covered under the New Vehicle Limited Warranty or the Emission Control System Warranty.

NOTE:

- To help clean the air, Suzuki recommends that you use the oxygenated fuels.
- Be sure that any oxygenated fuel you use has octane ratings of at least 87 pump octane ((R+M)/2 method).
- If you are not satisfied with the driveability of your motorcycle when you are using an oxygenated fuel, or if engine ping is experienced, substitute another brand as there are differences between brands.

CAUTION

Spilled gasoline containing alcohol can harm your motorcycle. Alcohol can damage painted surfaces.

Be careful not to spill any fuel when filling the fuel tank. Wipe spilled gasoline up immediately.

ENGINE OIL

Use a premium quality 4-stroke motor oil to ensure longer service life of your motorcycle. Use only oils which are rated SF or SG under the API service classification. The recommended viscosity is SAE 10W-40. If a SAE 10W-40 motor oil is not available, select an alternative according to the following chart.

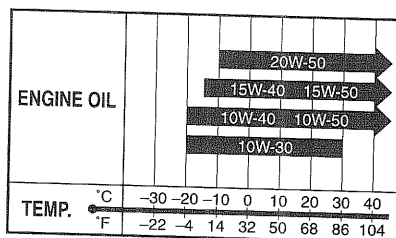

COOLANT

Use an anti-freeze compatible with aluminium radiator mixed with distilled water only at the ratio of 50:50.

WARNING

Engine coolant is harmful or fatal if swallowed or inhaled.

Do not drink antifreeze or coolant solution. If swallowed, do not induce vomiting. Immediately contact a poison control center or a physician. Avoid inhaling mist or hot vapors; if inhaled, remove to fresh air. If coolant gets in eyes, flush eyes with water and seek medical attention. Wash thoroughly after handling. Solution can be poisonous to animals. Keep out of the reach of children and animals.

CAUTION

Spilled engine coolant can damage painted surfaces.

Do not spill any fluid when filling the radiator. Wipe spilled engine coolant up immediately.

Water for mixing

Use distilled water only. Water other than distilled water can corrode and clog the aluminium radiator.

Anti-freeze

The coolant performs as rust inhibitor and water pump lubricant as well as anti-freeze. Therefore the coolant should be used at all times even though the atmospheric temperature in your area does not go down to freezing point.

Required amount of water/coolant

Solution capacity (total): 3000 ml (6.4/5.2 US/Imp. pt)

	Water	1500 ml (3.2/2.6 US/Imp. pt)
50 %	Coolant	1500 ml (3.2/2.6 US/Imp. pt)

NOTE: This 50 % mixture will protect the cooling system from freezing at temperatures above -31°C . If the motorcycle is to be exposed to temperature below -31°C , this mixing ratio should be increased up to 55 % (-40°C) or 60 % (-55°C). The mixing ratio should not exceed 60 %.

BREAK-IN (RUNNING-IN)

Previous sections explain how important proper break-in is to achieving maximum life and performance from your new Suzuki. The following guidelines explain proper break-in procedures.

MAXIMUM ENGINE SPEED RECOMMENDATION

This table shows the maximum recommended engine speed during the break-in period.

Initial	800 km (500 miles)	Below 7500 rpm
Up to	1600 km (1000 miles)	Below 11000 rpm
Over	1600 km (1000 miles)	Below 15500 rpm

VARY THE ENGINE SPEED

The engine speed should be varied and not held at a constant speed. This allows the parts to be "loaded" with pressure, and then unloaded, allowing the parts to cool. This aids the mating process of the parts. It is essential that some stress be placed on the engine components during break-in to ensure this mating process. Do not, though, apply excessive load on the engine.

BREAKING IN THE NEW TIRES

New tires need proper break-in to assure maximum performance, just as the engine does. Wear in the tread surface by gradually increasing your cornering lean angles over the first 160 km (100 miles) before attempting maximum performance. Avoid hard acceleration, hard cornering, and hard braking for the first 160 km (100 miles).

⚠ WARNING

Failure to perform break-in of the tires could cause tire slip and loss of control.

Use extra care when riding on new tires. Perform proper break-in of the tires as described in this section and avoid hard acceleration, hard cornering, and hard braking for the first 160 km (100 miles).

AVOID CONSTANT LOW SPEED

Operating the engine at constant low speed (light load) can cause parts to glaze and not seat in. Allow the engine to accelerate freely through the gears, without exceeding the recommended maximum limits. Do not, however, use full throttle for the first 1600 km (1000 miles).

ALLOW THE ENGINE OIL TO CIRCULATE BEFORE RIDING

Allow sufficient idling time after warm or cold engine start up before applying load or revving the engine. This allows time for the lubricating oil to reach all critical engine components.

OBSERVE YOUR FIRST AND MOST CRITICAL SERVICE

The initial service (1000 km maintenance) is the most important service your motorcycle will receive. During break-in operation, all of the engine components will have mated together and seated. Maintenance required as part of the initial service includes correction of all adjustments, tightening of all fasteners and replacement of dirty oil. Timely performance of this service will help make sure you get the best service life and performance from the engine.

NOTE: The 1000 km (600 miles) service should be performed as outlined in the INSPECTION AND MAINTENANCE section of this Owner's Manual. Pay particular attention to the CAUTION and WARNING in that section.

INSPECTION BEFORE RIDING

⚠ WARNING

Failure to inspect and maintain your motorcycle properly increases the chance of an accident or equipment damage.

Always perform a pre-ride inspection before each ride. Refer to the table below for check items. For further details, refer to the INSPECTION AND MAINTENANCE section.

⚠ WARNING

Using worn, improperly inflated, or incorrect tires will reduce stability and can cause an accident.

Follow all instructions in the TIRES section in this owner's manual.

Before riding the motorcycle, be sure to check the following items. Never underestimate the importance of these checks. Perform all of them before riding the motorcycle.

⚠ WARNING

Checking maintenance items when the engine is running can be hazardous. You could be severely injured if your hands or clothing get caught in moving parts.

Shut the engine off when performing maintenance checks, except when checking the engine stop switch and throttle.

WHAT TO CHECK	CHECK FOR:
Steering	<ul style="list-style-type: none">• Smoothness• No restriction of movement• No play or looseness
Throttle	<ul style="list-style-type: none">• Correct play in the throttle cable• Smooth operation and positive return of the throttle grip to the closed position
Clutch	<ul style="list-style-type: none">• Correct lever play• Smooth and progressive action
Brakes	<ul style="list-style-type: none">• Fluid level in the reservoir to be above "LOWER" line• Correct pedal and lever play• No "sponginess"• No fluid leakage• Brake pads not to be worn down to the limit line
Suspension	Smooth movement
Fuel	Enough fuel for the planned distance of operation
Drive chain	<ul style="list-style-type: none">• Correct tension or slack• Adequate lubrication• No excessive wear or damage
Tires	<ul style="list-style-type: none">• Correct pressure• Adequate tread depth• No cracks or cuts
Engine oil	Correct level
Cooling system	<ul style="list-style-type: none">• Proper coolant level• No coolant leakage
Lighting	Operation of all lights and indicators
Horn	Correct function
Engine stop switch	Correct function
Side stand/ Ignition interlock switch	Proper operation

RIDING TIPS

STARTING THE ENGINE

Before attempting to start the engine, make sure:

- The transmission is in neutral.
- The engine stop switch is in the "O" position.

NOTE: This motorcycle is equipped with interlock switches for the ignition circuit and the starter circuit.

The engine can only be started if:

- The transmission is in neutral and the clutch is disengaged, or
- The transmission is in gear, the side stand is fully up and the clutch is disengaged.

When the Engine is Cold:

1. Close the throttle completely and push the electric starter button.
2. After the engine starts, let the engine run until the engine sufficiently warms up.

When the Cold Engine is Hard to Start:

1. Open the throttle approximately 1/8 turn and push the electric starter button.
2. After the engine starts, let the engine run until the engine sufficiently warms up.

When the Engine is Warm:

Close the throttle completely and push the electric starter button.

When the Warm Engine is Hard to Start:

Open the throttle approximately 1/8 turn and push the electric starter button.

⚠ WARNING

Running the engine indoors or in a garage can be hazardous. Exhaust gas contains carbon monoxide, a gas that is colorless and odorless and can cause death or severe injury.

Only run the engine outdoors where there is fresh air.

CAUTION

Running the engine too long without riding may cause the engine to overheat. Overheating can result in damage to internal engine components and discoloration of exhaust pipes.

Shut the engine off if you cannot begin your ride promptly.

STARTING OFF

⚠ WARNING

Riding this motorcycle at excessive speed increases your chances of losing control of the motorcycle. This may result in an accident.

Always ride within the limits of your skills, your motorcycle, and the riding conditions.

⚠ WARNING

Removing your hands from the handlebars or feet from the footrests during operation can be hazardous. If you remove even one hand or foot from the motorcycle, you can reduce your ability to control the motorcycle.

Always keep both hands on the handlebars and both feet on the footrests of your motorcycle during operation.

⚠ WARNING

Sudden side winds, which can occur when being passed by larger vehicles, at tunnel exits or in hilly areas, can upset your control.

Reduce your speed and be alert to side winds.

After moving the side stand to the fully up position, squeeze the clutch lever and pause momentarily. Engage first gear by depressing the gear shift lever downward. Twist the throttle grip toward you and at the same time release the clutch lever gently and smoothly. As the clutch engages, the motorcycle will start moving forward. To shift to the next higher gear, accelerate gently, then close the throttle and squeeze the clutch lever simultaneously. Lift the gear shift lever upward to select the next gear, release the clutch lever and open the throttle again. Select the gears in this manner until top gear is reached.

NOTE: This motorcycle is equipped with a side stand/ignition interlock switch. If you shift the transmission into gear when the side stand is down, the engine will stop running.

USING THE TRANSMISSION

The transmission is provided to keep the engine operating smoothly in its normal operating speed range. The gear ratios have been carefully chosen to meet the characteristics of the engine. The rider should always select the most suitable gear for the prevailing conditions. Never slip the clutch to control road speed, but rather downshift to allow the engine to run within its normal operational range.

(For Canada)

The table below shows the approximate speed range for each gear.

Shifting up schedule

Gear position	km/h	miles/h
1st → 2nd	20	12
2nd → 3rd	30	19
3rd → 4th	40	25
4th → 5th	50	31
5th → 6th	60	37

Shifting down schedule

Gear position	km/h	miles/h
6th → 5th	50	31
5th → 4rd	40	25
4th → 3rd	30	19

Disengage the clutch when the motorcycle speed drops below 20 km/h (12 miles/h).

⚠ WARNING

Downshifting when engine speed is too high can;

- **cause the rear wheel to skid and lose traction due to increased engine braking, resulting in an accident; or**
- **force the engine to overrev in the lower gear, resulting in engine damage.**

Reduce speed before downshifting.

⚠ WARNING

Downshifting while the motorcycle is leaned over in a corner may cause rear wheel skid and loss of control.

Reduce your speed and downshift before entering the corner.

CAUTION

Revvng the engine into the red zone can cause severe engine damage.

Never allow the engine to rev into the red zone in any gear.

RIDING ON HILLS

- When climbing steep hills, the motorcycle may begin to slow down and show lack of power. At this point you should shift to a lower gear so that the engine will again be operating in its normal power range. Shift rapidly to prevent the motorcycle from losing momentum.
- When descending a long, steep slope, use engine compression to assist the brakes by shifting to a lower gear. Continuous brake application can overheat the brakes and reduce their effectiveness.
- Be careful, however, not to allow the engine to over rev.

STOPPING AND PARKING

1. Twist the throttle grip away from yourself to close the throttle completely.
2. Apply the front and rear brakes evenly and at the same time.
3. Downshift through the gears as road speed decreases.
4. Select neutral with the clutch lever squeezed toward the grip (disengaged position) just before the motorcycle stops. Neutral position can be confirmed by observing the neutral indicator light.

⚠ WARNING

Inexperienced riders tend to underutilize the front brake. This can cause excessive stopping distance and lead to a collision. Using only the front or rear brake can cause skidding and loss of control.

Apply both brakes evenly and at the same time.

⚠ WARNING

Hard braking while turning may cause wheel skid and loss of control.

Brake before you begin to turn.

⚠ WARNING

Hard braking on wet, loose, rough, or other slippery surfaces can cause wheel skid and loss of control.

Brake lightly and with care on slippery or irregular surfaces.

⚠ WARNING

Following another vehicle too closely can lead to a collision. As vehicle speeds increase, stopping distance increases progressively.

Be sure you have a safe stopping distance between you and the vehicle in front of you.

5. Park the motorcycle on a firm, flat surface where it will not fall over.

⚠ WARNING

A hot muffler can burn you. The muffler will be hot enough to burn you for some time after stopping the engine.

Park the motorcycle where pedestrians or children are not likely to touch the muffler.

NOTE: If the motorcycle is to be parked on the side stand on a slight slope, the front end of the motorcycle should face "up" the incline to avoid rolling forward off the side stand. You may leave the motorcycle in 1st gear to help prevent it from rolling off the side stand. Return to neutral before starting engine.

6. Turn the ignition key to the "OFF" position.
7. Turn the handlebars all the way to the left and lock the steering for security.
8. Remove the ignition key.

INSPECTION AND MAINTENANCE

MAINTENANCE SCHEDULE

The chart indicates the intervals between periodic services in miles, kilometers and months. At the end of each interval, be sure to inspect, check, lubricate and service as instructed. If your motorcycle is used under high stress conditions such as continuous full throttle operation, or is operated in a dusty climate, certain services should be performed more often to ensure reliability of the machine as explained in the maintenance section. Your Suzuki dealer can provide you with further guidelines. Steering components, suspensions and wheel components are key items and require very special and careful servicing. For maximum safety we suggest that you have these items inspected and serviced by your authorized Suzuki dealer or a qualified service mechanic.

⚠ WARNING

Improper maintenance or failure to perform recommended maintenance increases the chance of an accident or motorcycle damage.

Always follow the inspection and maintenance recommendations and schedules in this owner's manual. Ask your SUZUKI dealer or qualified mechanic to do the maintenance items marked with an asterisk (*). You may perform the unmarked maintenance items by referring to the instructions in this section, if you have mechanical experience. If you are not sure how to do any of the jobs, have your SUZUKI dealer or qualified mechanic do them.

⚠ WARNING

Running the engine indoors or in a garage can be hazardous. Exhaust gas contains carbon monoxide, a gas that is colorless and odorless and can cause death or severe injury.

Only run the engine outdoors where there is fresh air.

NOTE: The MAINTENANCE CHART specified the minimum requirements for maintenance. If you use your motorcycle under severe conditions, perform maintenance more often than shown in the chart. If you have any questions regarding maintenance intervals, consult your SUZUKI dealer or qualified mechanic.

CAUTION

Using poor quality replacement parts can cause your motorcycle to wear more quickly and may shorten its useful life.

Use only genuine Suzuki replacement parts or their equivalent.

MAINTENANCE CHART

Interval: This interval should be judged by odometer reading or months, whichever comes first.

Element	Interval		1000	6000	12000	18000	24000
	km						
	miles	months	600	4000	7500	11000	14500
Air cleaner element			—			R	
* Exhaust pipe bolts and muffler bolts			T	—	T	—	T
* Valve clearance			—	—	—	—	
Spark plugs			—		R		R
Fuel line			—				
			*Replace every 4 years				
Engine oil			R	R	R	R	R
Engine oil filter			R	—	—	R	—
Idle speed							
Throttle cable play							
* Throttle valve synchronization			—	—	—	—	
PAIR (air supply) system			—	—		—	
* Engine coolant			Replace every 2 years				
Radiator hose			—				
			Replace every 4 years				
Clutch cable play			—				
Drive chain							
			Clean and lubricate every 1000 km (600 miles)				
* Brakes							
Brake hose			—				
			*Replace every 4 years				
Brake fluid			—				
			*Replace every 2 years				
Tires			—				
* Steering				—		—	
* Front forks			—	—		—	
* Rear suspension			—	—		—	
* Chassis bolts and nuts			T	T	T	T	T

NOTE: | = Inspect and clean, adjust, replace or lubricate as necessary, R = Replace, T = Tighten

TOOLS

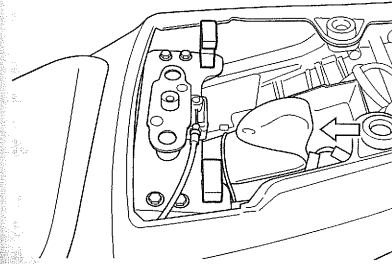

To assist you in the performance of periodic maintenance, a tool kit is supplied and located under the rear seat.

STEERING DAMPER MAINTENANCE

1. Keep the steering damper shaft clean at all times.
2. Wipe off any oil residue with a cloth ①.

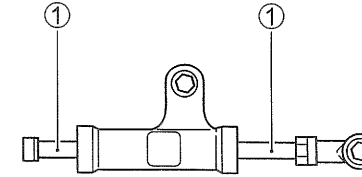

NOTE: Do not confuse the grease-like residue on the steering damper's shaft with an oil leak. Collection of this residue is normal and is from oil seal lubricant used in the damper.

You may also notice a sound as the damper shaft is stroked in and out. This "escaping air" type sound is normal and is made as the internal valving damps the shaft movement.

LUBRICATION POINTS

Proper lubrication is important for smooth operation and long life of each working part of your motorcycle and also for safe riding. It is a good practice to lubricate the motorcycle after a long rough ride and after getting it wet in the rain or after washing it. Major lubrication points are indicated below.

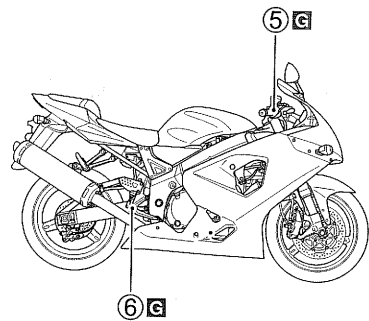
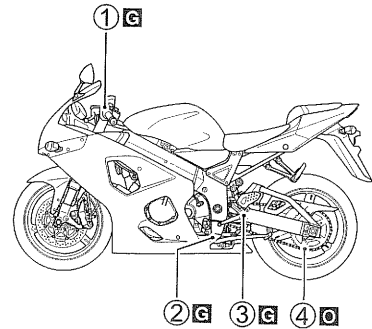

- ⓪ Motor oil
- ⓐ Grease

- ① Clutch lever holder
- ② Side stand pivot and spring hook
- ③ Gearshift lever pivot and footrest pivot
- ④ Drive chain
- ⑤ Brake lever holder
- ⑥ Brake pedal pivot and footrest pivot

BATTERY

The battery is located under the front seat. Remove the front seat by referring to the SEAT LOCK AND HELMET HOLDERS section. This battery is sealed type and requires no maintenance. Have your dealer check the battery's state of charge periodically.

The standard charging rate is 0.9A x 5 to 10 hours and maximum rate is 4.0A x 1 hour. Never exceed maximum charging rate.

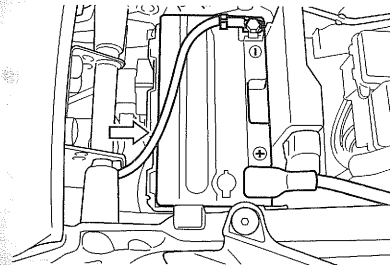

⚠ WARNING

Hydrogen gas produced by batteries can explode if exposed to flames or sparks.

Keep flames and sparks away from the battery. Never smoke when working near the battery.

CAUTION

Exceeding the maximum charging rate for the battery can shorten its life.

Never exceed the maximum charging rate.

CAUTION

Reversing the battery lead wires can damage the charging system and the battery.

The red lead must go to the positive (+) terminal and the black (or black with white tracer) lead must go to the negative (-) terminal.

AIR CLEANER

The air cleaner is located under the fuel tank. If the element has become clogged with dust, intake resistance will increase with a resultant decrease in power output and an increase in fuel consumption. If driving under dusty conditions, the air cleaner element must be cleaned or replaced more frequently than maintenance schedule. Check and clean the air cleaner element periodically according to the following procedure.

▲ WARNING

Operating the engine without the air cleaner element in place could allow a flame to spit back from the engine to the air cleaner, or could allow dirt to enter the engine. This could cause a fire or severe engine damage.

Never run the engine without the air cleaner element properly installed.

CAUTION

Clean or replace the air cleaner element frequently if the motorcycle is used in dusty, wet or muddy conditions. The air cleaner element will clog under these conditions, and this may cause engine damage, poor performance, and poor fuel economy.

Clean the air cleaner case and element immediately if water gets in the air cleaner box.

46

1. Place the motorcycle on the side stand.
2. Remove the front seat by referring to the SEAT LOCK AND HELMET HOLDERS section.

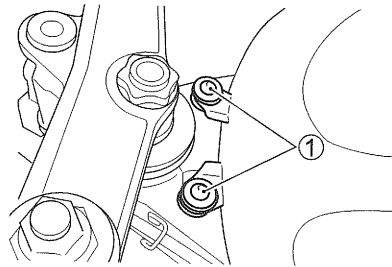

3. Remove the fuel tank fitting bolts (1).

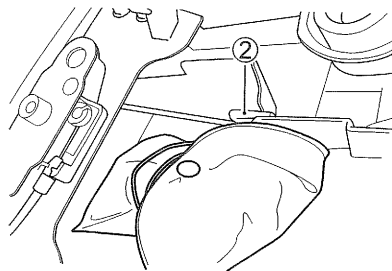

4. Remove the prop stay (2).

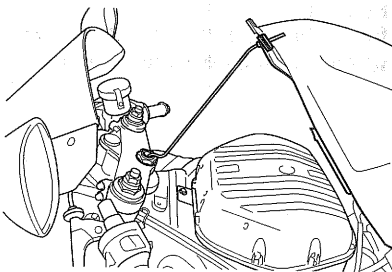

5. Lift the front end of the fuel tank and prop it up as shown above. Insert the crank end of the prop stand into the hole of the steering shaft.

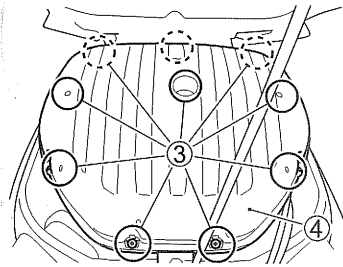

6. Remove the ten screws (3).
7. Remove the cover (4).

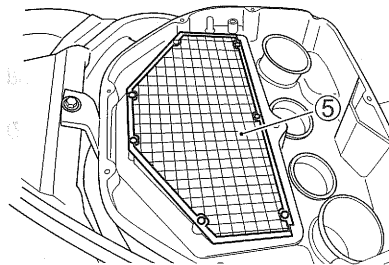

8. Remove the air cleaner element (5).

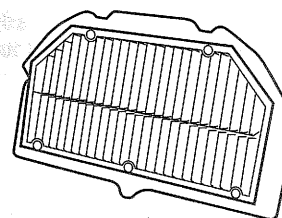

9. Inspect the air cleaner element condition. Replace the air cleaner element periodically.

10. Reinstall the cleaned element or new air cleaner element in reverse order of removal. Be absolutely sure that the element is securely in position and is sealing properly.

CAUTION

A torn air cleaner element will allow dirt to enter the engine and can damage the engine.

Carefully examine the air cleaner element for tears during cleaning. Replace it with a new one if it is torn.

CAUTION

Failure to position the air cleaner element properly can allow dirt to bypass the air cleaner element. This will cause engine damage.

Be sure to properly install the air cleaner element.

47

SPARK PLUGS

REMOVAL

To remove the spark plugs, follow the procedure below:

1. Lift the fuel tank by referring to the AIR CLEANER section.

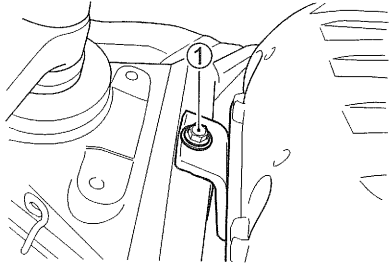

2. Remove the bolt ①.

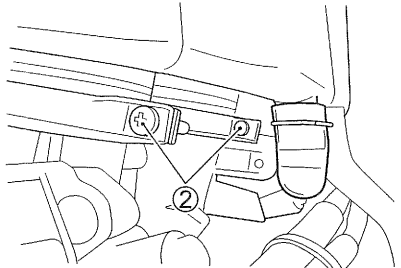

3. Loosen the screws ②.

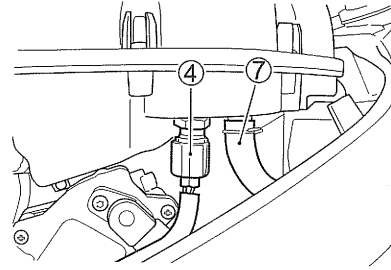
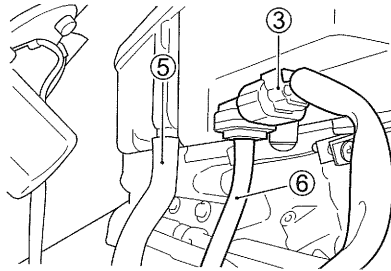

4. Disconnect the couplers ③ and ④.
5. Pull the three tubes ⑤, ⑥ and ⑦ off the air cleaner box.
6. Remove the air cleaner box.

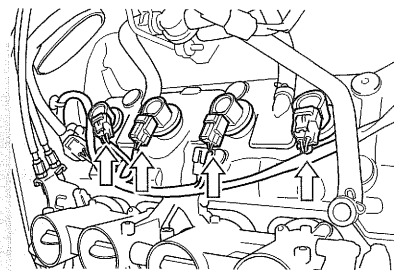

7. Release the connector locks and disconnect the connectors from the spark plug caps.

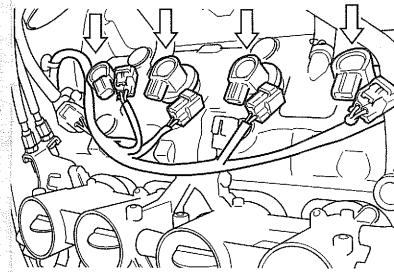

8. Extract the spark plug caps.

CAUTION

Improper removal of spark plug cap can damage the ignition coil in the spark plug cap.

Extract the spark plug cap with your hand. Do not use pliers.

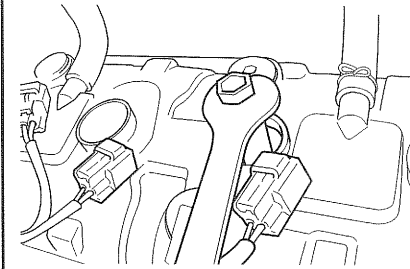

9. Remove the spark plug with the spark plug wrench provided in the tool kit.

CAUTION

Dirt can damage your engine if it enters an open spark plug hole.

Cover the spark plug hole whenever the spark plug is removed.

INSPECTION

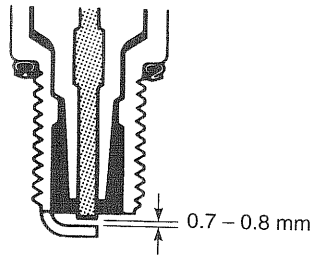
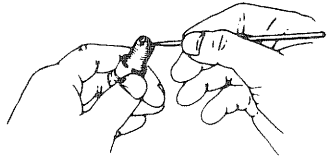

Remove the carbon deposits periodically from the spark plug with a piece of hard wire or pin. Readjust the spark plug gap to 0.7 - 0.8 mm (0.028 - 0.031 in) by using a spark plug gap thickness gauge. The spark plug should be replaced every 12000 km (7500 miles).

Whenever removing the carbon deposits, be sure to observe the operational color of each spark plug's porcelain tip. This color tells you whether or not the standard spark plug is suitable for your type of usage. A normal operating spark plug should be very light brown in color. If the spark plug is very white or glazed appearing, it has been operating much too hot. This spark plug should be replaced with the colder plug.

Plug Replacement Guide

CAUTION

An improper spark plug may have an incorrect fit or heat range for your engine. This may cause severe engine damage which will not be covered under warranty.

Use one of the spark plugs listed below or equivalent. Consult your Suzuki dealer or qualified mechanic if you are not sure which spark plug is correct for type of usage.

NGK	DENSO	REMARKS
CR8E	U24ESR-N	If the standard plug is apt to get wet, replace with this plug.
CR9E	U27ESR-N	Standard
CR10E	U31ESR-N	If the standard plug is apt to overheat, replace with this plug.

NOTE: This motorcycle uses resistor-type spark plug to avoid jamming electronic parts. Improper spark plug selection may cause electronic interference with your motorcycle ignition system, resulting in motorcycle performance problems. Use recommended spark plugs.

Installation

CAUTION

A crossthreaded or overtightened spark plug will damage the aluminum threads of the cylinder head.

Follow the procedure below to tighten the spark plug properly.

Carefully turn the spark plug by hand into the threads until it is finger tight. If the spark plug is new, tighten it with a wrench about 1/2 turn past finger tight. If you are reusing the old spark plug, tighten it with a wrench about 1/8 turn past finger tight.

CAUTION

Improper installation of spark plug cap can damage the ignition coil in the spark plug cap.

Install the spark plug caps with your hand. Never hit the spark plug caps with a tool.

Reinstall the air cleaner box and fuel tank in the reverse order of removal.

FUEL HOSE

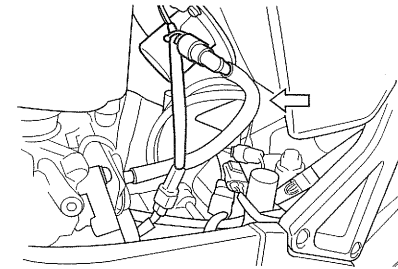

Inspect the fuel hose for damage and fuel leakage. If any defects are found, the fuel hose must be replaced.

ENGINE OIL

Long engine life depends much on the selection of a quality oil and the periodic changing of the oil. Daily oil level checks and periodic changes are two of the most important maintenance items to be performed.

ENGINE OIL LEVEL CHECK

Follow the procedure below to inspect the engine oil level.

1. Start the engine and run it for a few minutes.
2. Stop the engine and wait three minutes.

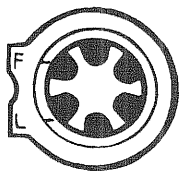

3. Hold the motorcycle vertically and inspect the engine oil level through the engine oil level inspection window on the right side of the engine.

CAUTION

The engine oil level must be between the "L" (Low) line and "F" (Full) line, or engine damage may occur.

Check the oil level, through the inspection window, with the motorcycle held vertically on level ground before each use of the motorcycle.

52

ENGINE OIL AND FILTER CHANGE

Change the engine oil and oil filter at the initial 1000 km (600 miles) and at each maintenance interval. The oil should be changed when the engine is warm so that the oil will drain thoroughly from the engine. The procedure is as follows:

1. Place the motorcycle on the side stand.

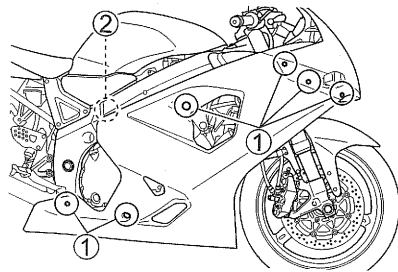

2. Remove the 6 screws ① and hook ②.

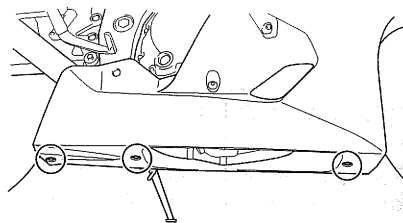

3. Remove the three fasteners.

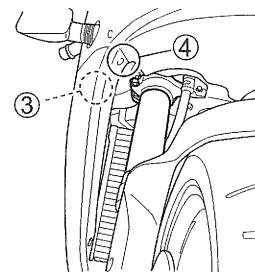

4. Remove the screw ③ and fastener ④.

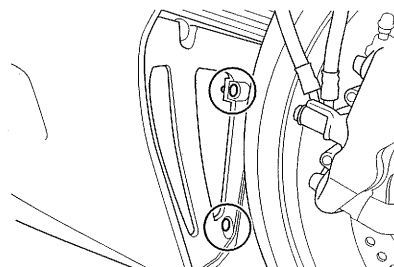

5. Remove the fasteners. Remove the right fairing.

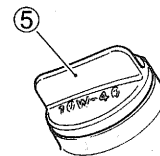

6. Remove the oil filler cap ⑤.

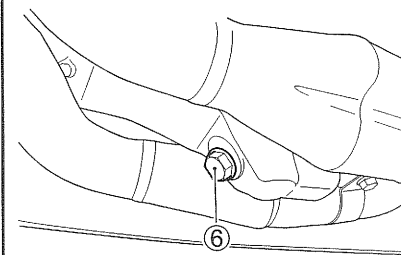

7. Place a drain pan under the drain plug ⑥.
8. Remove the drain plug with a wrench and drain out the engine oil.

WARNING

Engine oil and exhaust pipes can be hot enough to burn you.

Wait until the oil drain plug and exhaust pipes are cool enough to touch with bare hands before draining oil.

53

⚠ WARNING

New and used oil and solvent can be hazardous. Children and pets may be harmed by swallowing new or used oil or solvent. Continuous contact with used engine oil has been found to cause skin cancer in laboratory animals. Brief contact with used oil or solvent may irritate skin.

- Keep new and used oil and solvent away from children and pets.
- Wear a long-sleeve shirt and waterproof gloves.
- Wash with soap if oil or solvent contacts your skin.

NOTE: Recycle or properly dispose of used oil and solvent.

9. Reinstall the drain plug and gasket. Tighten the plug securely with a wrench.

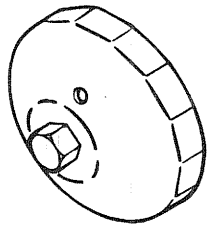

Available from Suzuki dealer
Oil filter wrench (Part No. 09915-40610)

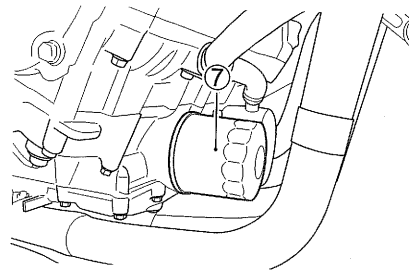

10. Turn the oil filter ⑦ counterclockwise and remove it with a Suzuki "cap type" oil filter wrench or a "strap type" filter wrench of proper size.

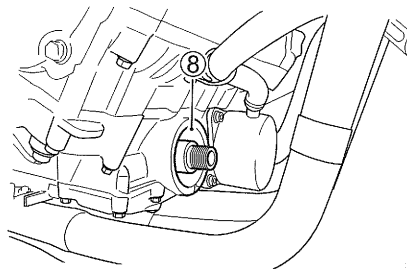

11. Wipe off the mounting surface ⑧ on the engine where the new filter will be seated with a clean rag.

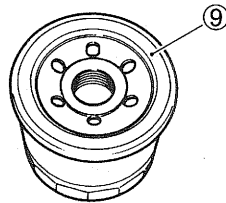

12. Smear a little engine oil around the rubber gasket ⑨ of the new oil filter.

54

13. Screw the new filter by hand until the filter gasket contacts the mounting surface (a small resistance will be felt).

CAUTION

Using an oil filter with the wrong design or thread specifications can cause oil leaks or engine damage.

Use a genuine SUZUKI oil filter or an equivalent designed for your motorcycle.

NOTE: To tighten the oil filter properly, it is important to accurately identify the position at which the filter gasket first contacts the mounting surface.

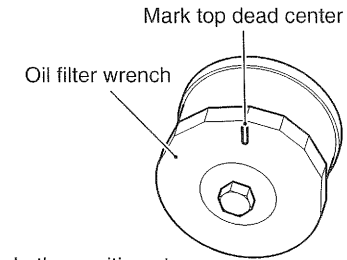

In the position at which the filter gasket first contacts the mounting surface.

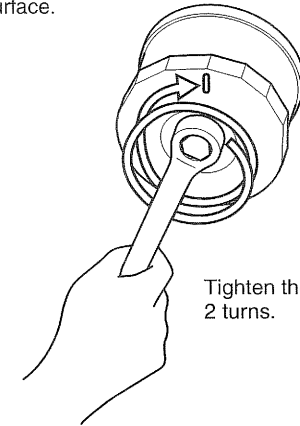

14. Mark the top dead center position on the "cap type" filter wrench or on the oil filter. Use an oil filter wrench to tighten the filter 2 turns.
15. Pour 3100 ml (3.3/2.7 US/Imp. qt) of new engine oil through the filler hole and install the filler cap. Be sure to always use the specified engine oil described in the FUEL AND ENGINE OIL section.

55

NOTE: About 2800 ml (3.0/2.5 US/ Imp. qt) of oil will be required when changing oil only.

CAUTION

Engine damage may occur if you use oil that does not meet Suzuki's specifications.

Use the oil specified in the FUEL, ENGINE OIL AND COOLANT RECOMMENDATION section.

16. With the engine running, look carefully for leaks at the oil filter and drain plug. Run the engine at various speeds for 2 to 3 minutes.
17. Stop the engine and wait a few minutes. Check the oil level again. Engine oil level can be inspected through the inspection window while holding the motorcycle vertically. If the oil level is lower than the "F" line, add new oil until it reaches the "F" line. Check for leaks again.

NOTE: If you do not have a proper oil filter wrench, have your Suzuki dealer perform this service.

IDLE SPEED

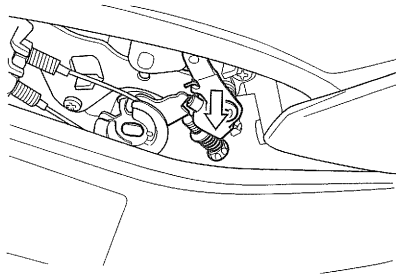

Adjust the engine idle speed periodically on the engine at normal operating temperature.

To adjust the idle speed:

1. Lift the fuel tank by referring to the AIR CLEANER section.
2. Start up the engine and let the engine run until it warms up fully.
3. After engine warms up, turn the throttle stop screw knob in or out so that engine may run at 1200 – 1400 r/min.

NOTE: The idle speed should be adjusted with the engine fully warmed up.

THROTTLE CABLE PLAY

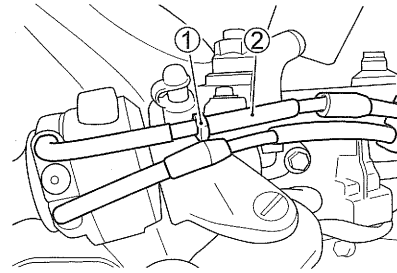
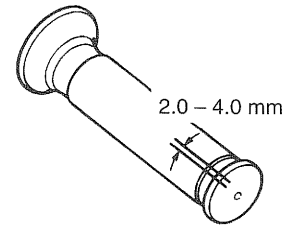

Minor Adjustment

1. Loosen the lock nut ①.
2. Turn the adjuster ② so that the throttle grip has 2.0 – 4.0 mm (0.08 – 0.16 in) play.

⚠ WARNING

Inadequate throttle cable play can cause engine speed to rise suddenly when you turn the handlebars. This can lead to loss of rider control.

Adjust the throttle cable play so that engine idle speed does not rise due to handlebars movement.

CLUTCH

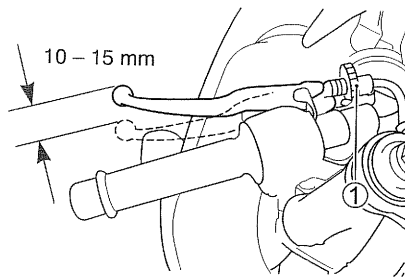

At each maintenance interval, adjust the clutch cable play with the clutch cable adjuster. The cable play should be 10 – 15 mm (0.4 – 0.6 in) as measured at the clutch lever end before the clutch begins to disengage. If you find the play of clutch incorrect, adjust it in the following way:

1. Turn clutch lever adjuster ① clockwise as far as it will go.

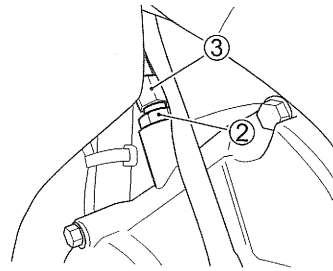

2. Loosen cable adjuster lock nut ②, and turn cable adjuster ③ to obtain approximately 10 – 15 mm (0.4 – 0.6 in) of free play at the clutch lever end as indicated.
3. Minor adjustment can now be made with the adjuster ①.
4. Tighten the lock nut ② after finishing adjustment.

NOTE: Any maintenance of the clutch other than the clutch cable play should be performed by your Suzuki dealer.

COOLANT COOLANT LEVEL

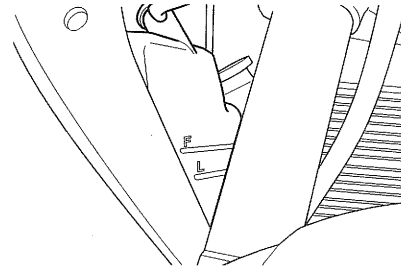

The coolant should be kept between the "F" (FULL) and "L" (LOW) level lines in the reservoir tank at all times. Inspect the level every time before riding with the motorcycle held vertically. If the coolant is found lower than the "L" level line, add properly mixed coolant in the following way:

1. Remove the right fairing. See ENGINE OIL section.

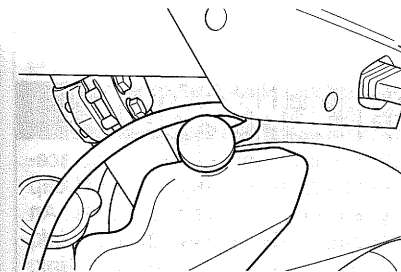

2. Remove the filler cap and add properly mixed coolant through the filler hole until it reaches the "F" line. Refer to the FUEL, ENGINE OIL AND COOLANT RECOMMENDATION section.

⚠ WARNING

Engine coolant is harmful or fatal if swallowed or inhaled.

Do not drink antifreeze or coolant solution. If swallowed, do not induce vomiting. Immediately contact a poison control center or a physician. Avoid inhaling mist or hot vapors; if inhaled, remove to fresh air. If coolant gets in eyes, flush eyes with water and seek medical attention. Wash thoroughly after handling. Solution can be poisonous to animals. Keep out of the reach of children and animals.

NOTE: Adding only water will dilute the engine coolant and reduce its effectiveness. Add 50:50 mixture of engine coolant and water.

CHANGING THE COOLANT

Change the coolant every two years.

NOTE: About 3000 ml (3.2/2.6 US/ Imp. qt) of coolant will required when filling the radiator and reservoir tank.

DRIVE CHAIN

This motorcycle has an endless drive chain constructed from special materials. It does not use a master link. We recommend that you take your motorcycle to an authorized Suzuki dealer or qualified mechanic if the drive chain needs replacing.

The condition and adjustment of the drive chain should be checked each day before you ride. Always follow the guide lines for inspecting and servicing the chain.

⚠ WARNING

Riding with the chain in poor condition or improperly adjusted can lead to an accident.

Inspect, adjust, and maintain the chain properly before each ride, according to this section.

Inspecting the Drive Chain

When inspecting the chain, look for the following:

- Loose pins
- Damaged rollers
- Dry or rusted links
- Kinked or binding links
- Excessive wear
- Improper chain adjustment

If you find anything wrong with the drive chain condition or adjustment, correct the problem if you know how. If necessary, consult your authorized Suzuki dealer or qualified mechanic.

Damage to the drive chain means that the sprockets may also be damaged. Inspect the sprockets for the following:

- Excessively worn teeth
- Broken or damaged teeth
- Loose sprocket mounting nuts

If you find any of these problems with your sprocket, consult your Suzuki dealer or qualified mechanic.

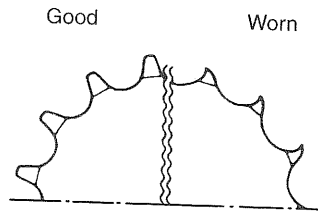

NOTE: The two sprockets should be inspected for wear when a new chain is installed and replace them if necessary.

⚠ WARNING

Improperly installing a replacement chain, or using a joint-clip type chain, can be hazardous. An incompletely riveted master link, or a joint-clip type master link, may come apart and cause an accident or severe engine damage.

Do not use a joint-clip type chain. Chain replacement requires a special riveting tool and a high-quality, non-joint-clip type chain. Ask an authorized SUZUKI dealer or qualified mechanic to perform this work.

DRIVE CHAIN CLEANING AND OILING

This drive chain has special "O" rings that permanently seal grease inside. Clean and oil the chain periodically, as follows:

1. Clean the chain with kerosene. If the chain tends to rust, the interval must be shortened. Kerosene is a petroleum product and will provide some lubrication as well as cleaning action.

⚠ WARNING

Kerosene can be hazardous. Kerosene is flammable. Children or pets may be harmed from contact with kerosene.

Keep flames and smoking materials away from kerosene. Keep children and pets away from kerosene. If swallowed, do not induce vomiting. Call a physician immediately. Dispose of used kerosene properly.

CAUTION

Cleaning the chain with gasoline or commercial cleaning solvents can damage O-rings and ruin the chain.

Clean the drive chain with kerosene only.

2. After thoroughly washing the chain and allowing it to dry, oil the links with SUZUKI chain lube or an equivalent.

CAUTION

Some drive chain lubricants contain solvents and additives which could damage the O-rings in your chain.

Use Suzuki chain lube or an equivalent that is specifically intended for use with O-ring chains.

DRIVE CHAIN ADJUSTMENT

Adjust the drive chain slack to the proper specification. The chain may require more frequent adjustments than periodic maintenance schedule depending upon your riding conditions.

⚠ WARNING

Too much chain slack can cause the chain to come off the sprockets, resulting in an accident or serious damage to the motorcycle.

Inspect and adjust the drive chain slack before each use.

To adjust the drive chain, follow the procedure below:

1. Place the motorcycle on the side stand.

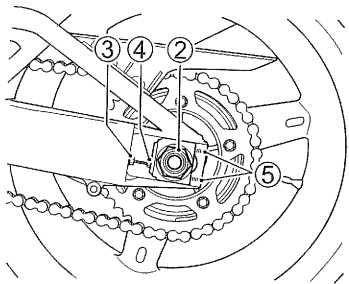

Except for Canada

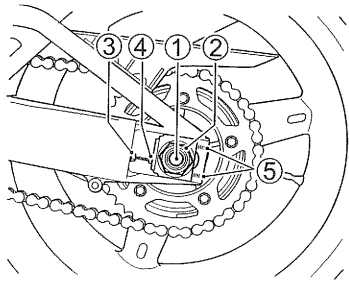

For Canada

2. (Only for Canada) Remove the cotter pin ①.
3. Loosen the axle nut ②.
4. Loosen the lock nut ③ (right and left).

⚠ WARNING

A hot muffler can burn you. The muffler will be hot enough to burn you for some time after stopping the engine.

Wait until the muffler cools to avoid burns.

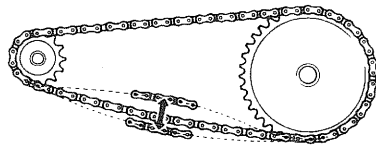

20 – 30 mm

5. Adjust the drive chain slack by turning the right and left chain adjuster bolts ④. At the same time that the chain is being adjusted, the rear sprocket must be kept in perfect alignment with the front sprocket. To assist you in performing this procedure, there are reference marks ⑤ on the swing arm and each chain adjuster which are to be aligned with each other and to be used as a reference from one side to the other.
6. Tighten the lock nut ③ (right and left).
7. Tighten the axle nut ② securely.
8. (Only for Canada) Replace the cotter pin with a new one.
9. Recheck the chain slack after tightening and readjust if necessary.

Rear axle nut tightening torque:
100 N·m (10.0 kgf·m, 72.5 lb·ft)

BRAKES

This motorcycle utilizes front and rear disk brakes. Proper operation of brake systems are vital to safe riding. Be sure to perform the brake inspection requirements as scheduled.

BRAKE SYSTEM

⚠ WARNING

Failure to inspect and properly maintain the brakes increases your chance of having an accident.

Inspect the brake system before each use according to the **INSPECTION BEFORE RIDING** section. Follow the **MAINTENANCE SCHEDULE** section to maintain your brake system.

Inspect your brake system for the following items daily:

- Inspect the fluid level in the reservoirs.
- Inspect the front and rear brake system for signs of fluid leakage.
- Inspect the brake hose for leakage or a cracked appearance.
- The brake lever and pedal should have the proper stroke and be firm at all times.
- Check the wear of the disk brake pads.

BRAKE FLUID

⚠ WARNING

Brake fluid is harmful or fatal if swallowed, and harmful if it comes in contact with skin or eyes.

If swallowed, do not induce vomiting. Immediately contact a poison control center or a physician. If brake fluid gets in eyes, flush eyes with water and seek medical attention. Wash thoroughly after handling. Solution can be poisonous to animals. Keep out of the reach of children and animals.

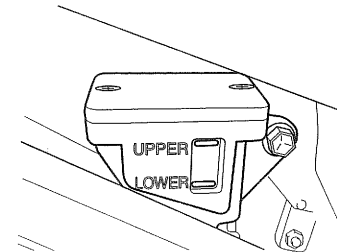
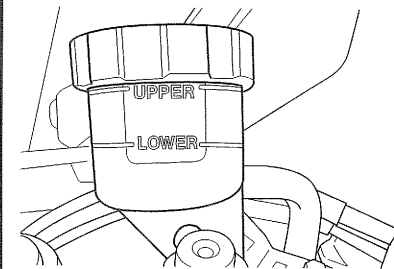

Check the brake fluid level in both front and rear brake fluid reservoirs. Inspect for brake pad wear and leaks.

⚠ WARNING

Failure to keep the brake fluid reservoir full with proper brake fluid can be hazardous. The brakes may not work correctly without the proper amount and type of brake fluid. This could lead to an accident.

Inspect the brake fluid level before each use. Use only DOT4 brake fluid from a sealed container. Never use or mix different types of brake fluid. If there is frequent loss of fluid, take your motorcycle to a SUZUKI dealer or qualified mechanic for inspection.

CAUTION

Spilled brake fluid can damage painted surfaces and plastic parts.

Avoid spilling any fluid when filling the reservoir. Wipe up spills immediately.

BRAKE PAD

FRONT

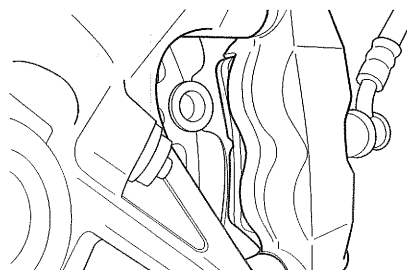

REAR

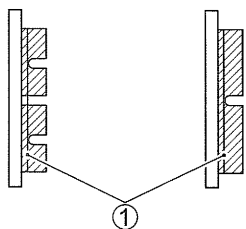
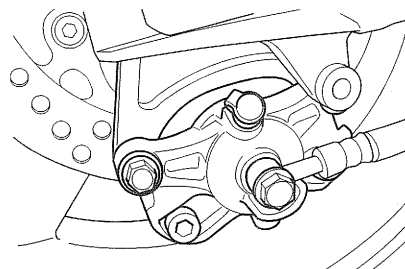

FRONT

REAR

Inspect the front and rear brake pads by noting whether or not the friction pads are worn down to the grooved limit line ①. If a pad is worn to the grooved limit line it must be replaced with a new one by your authorized Suzuki dealer or qualified service mechanic.

⚠ WARNING

Riding with worn brake pads will reduce braking performance and will increase your chance of having an accident.

Inspect brake pad wear before each use. Ask your SUZUKI dealer or qualified mechanic to replace brake pads if any pad is worn to the limit.

⚠ WARNING

Failure to extend brake pads after repair or replacement can cause poor braking performance and may result in an accident.

Before riding, "pump" the brake repeatedly until brake pads are pressed against the brake disks and proper lever/pedal stroke and firm feel are restored.

NOTE: Do not squeeze/depress the brake lever/pedal when the pads are not in their positions. It is difficult to push the pistons back and brake fluid leakage may result.

REAR BRAKE PEDAL ADJUSTMENT

The rear brake pedal position must be properly adjusted at all times or the disk brake pads will bear against the disk causing damage to the pads and to the disk surface. Adjust the brake pedal position in the following manner:

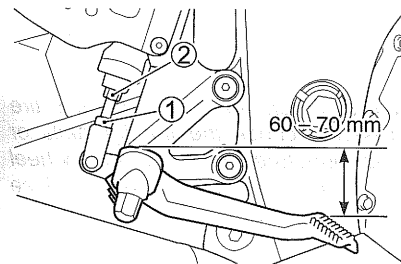

1. Loosen lock nut ①, and rotate push rod ② to locate the pedal 60 – 70 mm (2.4 – 2.8 in) below the top face of the footrest.
2. Retighten lock nut ① to secure push rod ② in the proper position.

CAUTION

An incorrectly adjusted brake pedal may force brake pads to rub against the disk at all times, causing damage to the pads and disk.

Follow the steps in this section to adjust the brake pedal properly.

REAR BRAKE LIGHT SWITCH

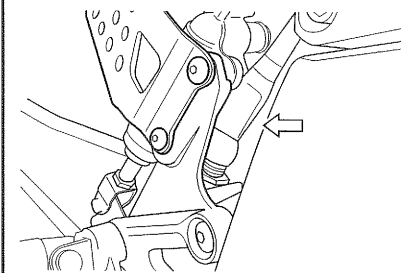

To adjust the brake light switch, raise or lower the switch so that the brake light will come on just before a pressure rise is felt when the brake pedal is depressed.

TIRES

⚠ WARNING

Failure to follow these warnings may result in an accident due to tire failure. The tires on your motorcycle form the crucial link between your motorcycle and the road.

Follow these instructions;

- Check tire condition and pressure, and adjust pressure before each ride.
- Avoid overloading your motorcycle.
- Replace a tire when worn to the specified limit, or if you find damage such as cuts or cracks.
- Always use the size and type of tires specified in this owner's manual.
- Balance the wheel after tire installation.
- Read this section of owner's manual carefully.

⚠ WARNING

Failure to perform break-in of the tires could cause tire slip and loss of control.

Use extra care when riding on new tires. Perform proper break-in of the tires referring to the **BREAK-IN** section and avoid hard acceleration, hard cornering, and hard braking for the first 160 km (100 miles).

TIRE PRESSURE AND LOADING

Proper tire pressure and proper tire loading are important factors. Overloading your tires can lead to tire failure and loss of vehicle control.

Check tire pressure each day before you ride, and be sure the pressure is correct for the vehicle load according to the table below. Tire pressure should only be checked and adjusted before riding, since riding will heat up the tires and lead to higher inflation pressure readings.

Under-inflated tires make smooth cornering difficult, and can result in rapid tire wear. Over-inflated tires have a smaller amount of tire in contact with the road, which can contribute to skidding and loss of control.

Cold Tire Inflation Pressure

LOAD TIRE	SOLO RIDING	TWO-UP RIDING
FRONT	250 kPa 2.50 kgf/cm ² 36 psi	250 kPa 2.50 kgf/cm ² 36 psi
REAR	250 kPa 2.50 kgf/cm ² 36 psi	250 kPa 2.50 kgf/cm ² 36 psi

NOTE: When you detect drops in tire pressure, check the tire for nails or other punctures, or a damaged wheel rim. Tubeless tires sometimes lose pressure gradually when punctured.

TIRE CONDITION AND TYPE

Proper tire condition and proper tire type affect vehicle performance. Cuts or cracks in the tires can lead to tire failure and loss of vehicle control. Worn tires are susceptible to puncture failures and subsequent loss of vehicle control. Tire wear also affects the tire profile, changing vehicle handling characteristics.

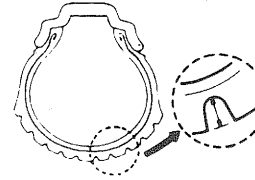

Check tire conditions each day before you ride. Replace tires if tires show visual evidence of damage, such as cracks or cuts, or if tread depth is less than 1.6 mm (0.06 in) front, 2.0 mm (0.08 in) rear.

NOTE: These wear limits will be reached before the wear bars molded into the tire make contact with the road.

When you replace a tire, be sure to replace it with a tire of the size and type listed below. If you use a different size or type of tire, vehicle handling may be adversely affected, possibly resulting in loss of vehicle control.

For Canada

	FRONT	REAR
SIZE	120/70 ZR17 M/C (58W)	180/55 ZR17 M/C (73W)
TYPE	DUNLOP D218F	DUNLOP D218

Except for Canada

	FRONT	REAR
SIZE	120/70 ZR17 M/C (58W)	180/55 ZR17 M/C (73W)
TYPE	BRIDGESTONE BT014F SF	BRIDGESTONE BT014R F

Be sure to balance the wheel after repairing a puncture or replacing the tire. Proper wheel balance is important to avoid variable wheel-to-road contact, and to avoid uneven tire wear.

⚠ WARNING

An improperly repaired, installed, or balanced tire can cause loss of control or shorten tire life.

- Ask your SUZUKI dealer or qualified mechanic to perform tire repair, replacement, and balancing because proper tools and experience are required.
- Install tires according to the rotation direction shown by arrows on the sidewall of each tire.

⚠ WARNING

Failure to follow these instructions about tubeless tires may result in an accident due to tire failure. Tubeless tires require different service procedures than tube tires.

- Tubeless tires require an airtight seal between the tire bead and wheel rim. Special tire irons and rim protectors or a specialized tire mounting machine must be used for removing and installing tires to prevent tire or rim damage which could result in an air leak.
- Repair puncture in tubeless tires by removing the tire and applying an internal patch.
- Do not use an external repair plug to repair a puncture since the plug may work loose as a result of the cornering forces experienced in a motorcycle tire.
- After repairing a tire, do not exceed 80 km/h (50 mph) for the first 24 hours, 130 km/h (80 mph) thereafter. This is to avoid excessive heat build-up which could result in a tire repair failure and tire deflation.
- Replace the tire if it is punctured in the sidewall area, or if a puncture in the tread area is larger than 6 mm (3/16 in). These punctures cannot be repaired adequately.

SIDE STAND/IGNITION INTERLOCK SWITCH

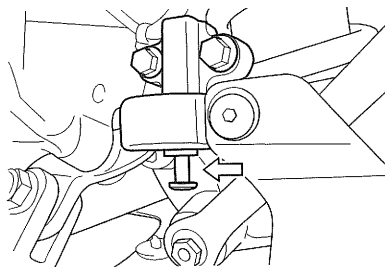

Check the side stand/ignition interlock switch for proper operation as follows:

1. Sit on the motorcycle in the normal riding position, with the side stand up.
2. Shift into first gear, hold the clutch in, and start the engine.
3. While continuing to hold the clutch in, move the side stand to the down position.

If the engine stops running when the side stand is moved to the down position, then the side stand/ignition interlock switch is working properly. If the engine continues to run with the side stand down and the transmission in gear, then the side stand/ignition interlock switch is not working properly. Have your motorcycle inspected by an authorized Suzuki dealer or a qualified service mechanic.

⚠ WARNING

If the side stand/ignition interlock system is not working properly, it is possible to ride the motorcycle with the side stand in the down position. This may interfere with rider control during a left turn.

Check the side stand/ignition interlock system for proper operation before riding. Check that the side stand is returned to its full up position before starting off.

FRONT WHEEL REMOVAL

1. Place the motorcycle on the side stand.

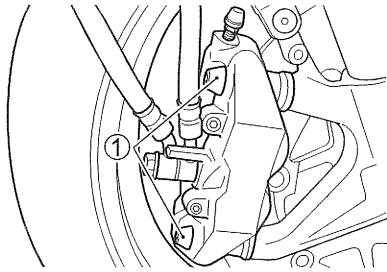

2. Remove both brake calipers from the front forks by removing two mounting bolts ① on each calipers.

NOTE: Never squeeze the front brake lever with the caliper removed. It is very difficult to force the pads back into the caliper assembly and brake fluid leakage may result.

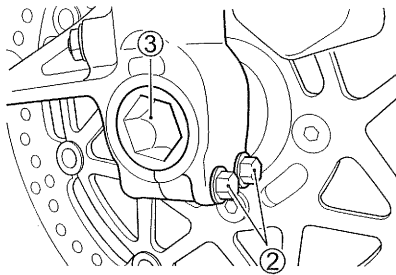

3. Loosen the two axle holder bolts ② on the right front fork.

NOTE: Never loosen the axle holder bolts on the left front fork.

4. Loosen the axle shaft ③ temporarily.

5. Place an accessory service stand or equivalent under the swing arm to help stabilize the rear end.
6. Carefully position a jack under the exhaust pipe and raise until the front wheel is slightly off the ground.

CAUTION

Improper jacking may cause damage to the fairing or oil filter.

Do not apply the jack head to the fairing lower part or the oil filter when jacking up the motorcycle.

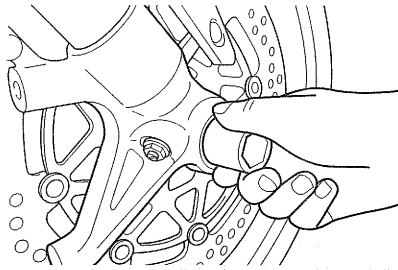

7. Turn the axle shaft counterclockwise and draw it out.

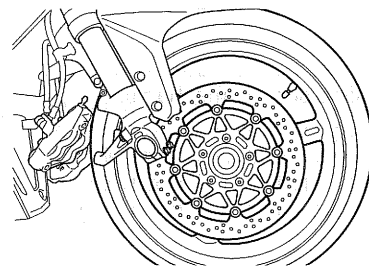

8. Slide the front wheel forward.

9. To reinstall the wheel assembly, reverse the sequence as described.
10. After installing the wheel, apply the brake several times to restore the proper lever stroke.

WARNING

Failure to extend brake pads after installing the wheel can cause poor braking performance and may result in an accident.

Before riding, "pump" the brake repeatedly until brake pads are pressed against the brake disks and proper lever/pedal stroke and firm feel are restored. Also check that the wheel rotates freely.

WARNING

Installing the front wheel in the reverse direction can be hazardous. The tire for this motorcycle is directional. Therefore, the motorcycle may have unusual handling if the wheel is installed incorrectly.

Install the front wheel in a specified direction, as indicated by the arrow on the sidewall of the tire.

WARNING

Failure to torque bolts and nuts properly could lead to an accident.

Torque bolts and nuts to the proper specifications. If you are not sure of the proper procedure, have your authorized SUZUKI dealer or qualified mechanic do this.

Front axle tightening torque:
100 N·m (10.0 kgf·m, 72.5 lb-ft)

Front axle holder bolt tightening torque:
23 N·m (2.3 kgf·m, 16.5 lb-ft)

Front brake caliper mounting bolt tightening torque:
39 N·m (3.9 kgf·m, 28.0 lb-ft)

REAR WHEEL REMOVAL

1. Place the motorcycle on the side stand.

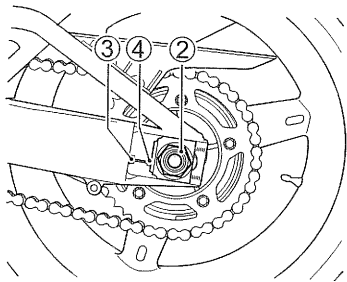

Except for Canada

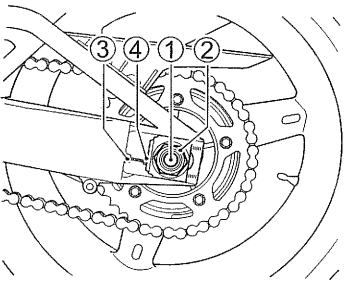

For Canada

2. (Only for Canada) Remove the cotter pin ①.
3. Remove the axle nut ②.

⚠ WARNING

A hot muffler can burn you. The muffler will be hot enough to burn you for some time after stopping the engine.

Wait until the muffler cools to avoid burns.

4. Place an accessory service stand or equivalent under the swing arm to lift the rear wheel slightly off the ground.
5. Loosen the lock nut ③ (right and left). Turn the chain adjusting nuts ④ clockwise (right and left).

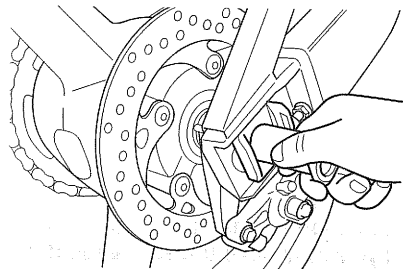

6. Draw out the axle shaft.

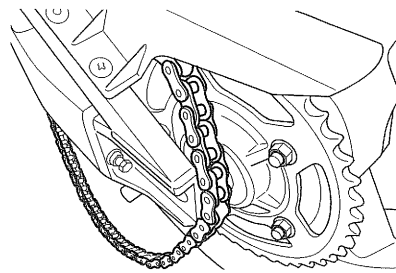

7. With the wheel moved forward, remove the chain from the sprocket.

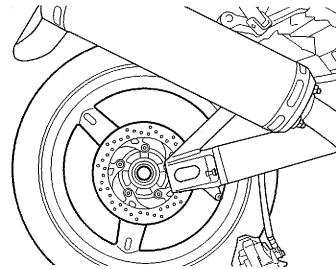

8. Pull the rear wheel assembly rearward.

NOTE: Never depress the rear brake pedal with the rear wheel removed. It is very difficult to force the pads back into the caliper assembly.

9. To replace the wheel reverse the complete sequence listed.
10. (Only for Canada) Replace the cotter pin with a new one.
11. After installing the wheel, apply the brake several times and then check that the wheel rotates freely.

⚠ WARNING

Failure to adjust the drive chain and failure to torque bolts and nuts properly could lead to an accident.

- Adjust the drive chain as described in DRIVE CHAIN ADJUSTMENT section after installing the rear wheel.
- Torque bolts and nuts to the proper specifications. If you are not sure of the proper procedure, have your authorized SUZUKI dealer or qualified mechanic do this.

Rear axle nut tightening torque:
120 N·m (12.0 kgf·m, 87.0 lb-ft)

⚠ WARNING

Failure to extend brake pads after installing the wheel can cause poor braking performance and may result in an accident.

Before riding, "pump" the brake repeatedly until brake pads are pressed against the brake disks and proper lever/pedal stroke and firm feel are restored. Also check that the wheel rotates freely.

LIGHT BULB REPLACEMENT

The wattage rating of each bulb is shown on the table below. When replacing a burned out bulb, always use the exact same wattage rating. Using other than the specified rating can result in overloading the electrical system or premature failure of a bulb.

CAUTION

Using a light bulb with the wrong wattage rating can cause electrical system damage or shorten bulb life.

Always use the specified light bulb.

Headlight	12V 55W (H7) ... Upper 12V 60/55W (H4) ... Lower
Position light	12V 5W ... EU
Turn signal light	12V 18W
Brake light/Taillight	LED

HEADLIGHT

To replace the headlight bulb, perform the following step:

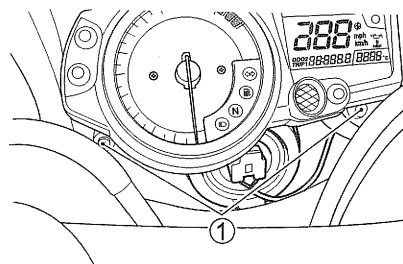

1. Remove the two bolts ①. Pull out the instrument panel (Upper headlight bulb only).

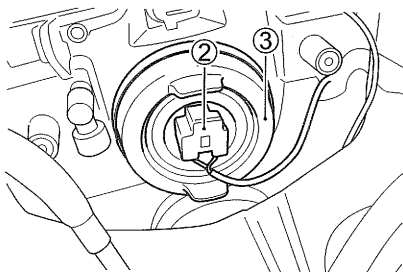

2. Disconnect the socket ② from the headlight and remove the rubber cap ③.

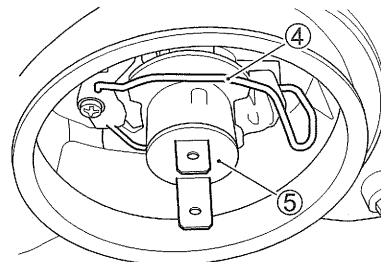

3. Unhook the bulb holder spring ④ and pull out the bulb ⑤.

CAUTION

Oil from your skin may damage the headlight bulb or shorten its life.

Grasp the new bulb with a clean cloth.

TURN SIGNAL LIGHT

To replace the turn signal light bulb, follow these directions.

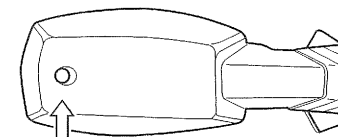

1. Remove the screw and take off the lens.

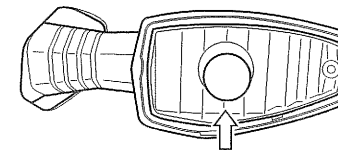

2. Pull off the bulb.
3. To fit the replacement bulb, push it in and twist it to the right while pushing.

CAUTION

Overtightening the screws may cause the lens to crack.

Tighten the screws only until they are snug.

FUSES

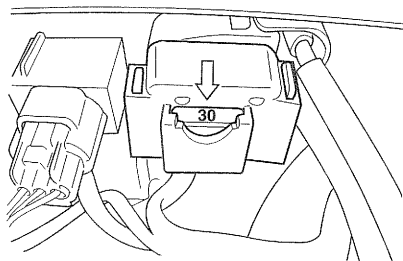

The main fuse is located under the front seat. To access the fuse, remove the seat by referring to the SEAT LOCK AND HELMET HOLDERS.

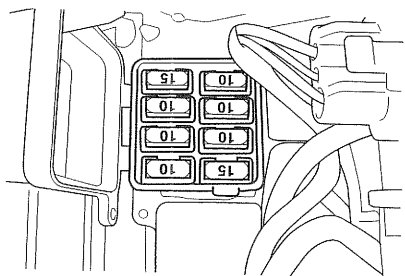

The fuses are located under the front seat. One 10A and one 15A spare fuses are provided inside the fuse box.

They are designed to open when a circuit overload exists in individual electrical system circuits. If any electrical system fails to operate, then the fuses must be checked.

CAUTION

Installing a fuse of incorrect rating or using aluminum foil or wire instead of a fuse may seriously damage the electrical system.

Always replace a blown fuse with a fuse of the same type and rating. If the new fuse blows in a short time, consult your Suzuki dealer or qualified mechanic immediately.

FUSE LIST

- 30A MAIN fuse protects all electrical circuits.
- 15A HEAD-HI fuse protects the headlight high beam and high beam indicator light. (Canada only)
- 10A HEAD-HI fuse protects the headlight high beam and high beam indicator light.
- 10A HEAD-LO fuse protects the headlight low beam.
- 15A IGNITION fuse protects the ignition coil.
- 10A SIGNAL fuse protects the speedometer, horn and brake light.
- 10A FUEL fuse protects the speedometer and fuel injection system.
- 10A FAN fuse protects the cooling fan motor.

TROUBLESHOOTING

This troubleshooting guide is provided to help you find the cause of some common complaints.

CAUTION

Failure to troubleshoot a problem correctly can damage your motorcycle. Improper repairs or adjustments may damage the motorcycle instead of fixing it. Such damage may not be covered under warranty.

If you are not sure about the proper action, consult your Suzuki dealer or qualified mechanic about the problem.

If the engine refuses to start, perform the following inspections to determine the cause.

Fuel Supply Check

If the fuel injection indicator displays "FI", showing signs of trouble in the fuel injection system, take your machine to an authorized Suzuki dealer. Refer to the "INSTRUMENT PANEL" section for fuel injection system indicator explanation. If the indicator does not display "FI", make sure there is enough fuel in the fuel tank. If the indicator does not display "FI" and there is enough fuel, ignition system should be checked.

Ignition System Check

1. Remove the spark plugs and reattach them to the spark plug caps.

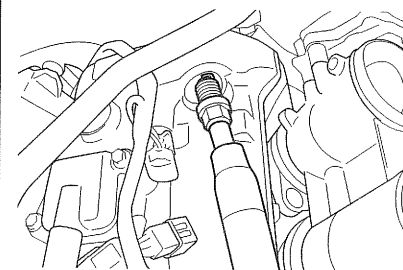

2. While holding the spark plug firmly against the crank case of the engine, push the starter switch with the ignition switch in the "ON" position, the engine stop switch in the "Q" position, the transmission in neutral, and the clutch disengaged. If the ignition system is operating properly, a blue spark should jump across the spark plug gap.
3. If there is no spark, clean the spark plug. Replace it if necessary. Retry the above procedure with the cleaned spark plug or new one.
4. If there is still no spark, consult your Suzuki dealer for repairs.

WARNING

Performing the spark test improperly can cause a high voltage electrical shock or an explosion.

Avoid performing this check if you are not familiar with this procedure, or if you have a heart condition or wear a pacemaker. Keep the spark plug away from the spark plug hole during this test.

ENGINE STALLING

1. Make sure there is enough fuel in the fuel tank.
2. If the fuel injection indicator displays "FI", showing signs of trouble in the fuel injection system, take your machine to an authorized Suzuki dealer. Refer to the "INSTRUMENT PANEL" section for fuel injection system indicator explanation.
3. Check the ignition system for intermittent spark.
4. Check the idle speed. If necessary, adjust it using a tachometer. The correct idle speed is 1200 – 1400 r/min.

MOTORCYCLE CLEANING

Washing the Motorcycle

When washing the motorcycle, follow the instruction below:

1. Remove dirt and mud from the motorcycle with running water. You may use a soft sponge or brush. Do not use hard materials which can scratch the paint.
2. Wash the entire motorcycle with a mild detergent or car wash soap using a sponge or soft cloth. The sponge or cloth should be frequently soaked in the soap solution.

CAUTION

Radiator fins can be damaged by spraying high pressure water on them.

Do not spray high pressure water on the radiator fins.

NOTE: Avoid spraying or allowing water to flow over the following places:

- Ignition switch
 - Spark plugs
 - Fuel tank cap
 - Fuel injection system
 - Brake master cylinders
3. Once the dirt has been completely removed, rinse off the detergent with running water.
 4. After rinsing, wipe off the motorcycle with a wet chamoise or cloth and allow it to dry in the shade.

5. Check carefully for damage to painted surfaces. If there is any damage, obtain "touch-up" paint and "touch-up" the damage following the procedure below:

- a. Clean all damaged spots and allow them to dry.
- b. Stir the paint and "touch-up" the damaged spots lightly with a small brush.
- c. Allow the paint to dry completely.

Windshield Cleaning

Clean the windshield with a soft cloth and warm water with a mild detergent. If scratched, polish with a commercially available plastic polish. Replace the windshield if it becomes scratched or discolored so as to obstruct view. When replacing the windshield, use a Suzuki replacement windshield.

CAUTION

Cleaning with any alkaline or strong acid cleaner, gasoline, brake fluid, or any other solvent will damage the windshield.

Clean only with a soft cloth and warm water with a mild detergent.

Waxing the Motorcycle

After washing the motorcycle, waxing and polishing are recommended to further protect and beautify the paint.

- Only use waxes and polishes of good quality.
- When using waxes and polishes, observe the precautions specified by the manufacturers.

Inspection after Cleaning

For extended life of your motorcycle, lubricate according to "LUBRICATION POINTS" section.

⚠ WARNING

Wet brakes can cause poor braking performance and may lead to an accident.

Avoid a possible accident by expecting longer stopping distances after washing your motorcycle. Apply brakes several times to let heat dry the brake pads or shoes.

Follow the procedures in the "INSPECTION BEFORE RIDING" section to check your motorcycle for any problems that may have arisen during your last ride.

STORAGE PROCEDURE

If the motorcycle is to be left unused for extended period of time for winter storage or any other reason, the machine needs special servicing requiring appropriate materials, equipment and skill. For this reason, Suzuki recommends that you trust this maintenance work to your Suzuki dealer. If you need to service the machine for storage yourself, follow the general guidelines below.

MOTORCYCLE

Clean the entire motorcycle. Place the motorcycle on the side stand on a firm, flat surface where it will not fall over.

FUEL

1. Fill the fuel tank to the top with fuel mixed with the amount of gasoline stabilizer recommended by the stabilizer manufacturer.
2. Run the engine for a few minutes until the stabilized gasoline fills the fuel injection system.

ENGINE

1. Pour one tablespoon of motor oil into each spark plug hole. Reinstall the spark plugs and crank the engine a few times.
2. Drain the engine oil thoroughly. Refill the crankcase with fresh engine oil all the way up to the filler hole.

BATTERY

1. Remove the battery from the motorcycle.

NOTE: Be sure to remove the negative terminal first, then remove the positive terminal.

2. Clean the outside of the battery with a mild detergent and remove any corrosion from the terminals and wiring harness connections.
3. Store the battery in a room above freezing.

TIRES

Inflate the tires to the normal specifications.

EXTERNAL

- Spray all vinyl and rubber parts with rubber preservative.
- Spray the unpainted surfaces with rust preventative.
- Coat the painted surfaces with car wax.

PROCEDURE DURING STORAGE

Once a month, recharge the battery with a specified charging rate (Ampere). Standard charging rate is 0.9A x 5 to 10 hours.

PROCEDURE FOR RETURNING TO SERVICE

- Clean the entire motorcycle.
- Reinstall the battery.

NOTE: Be sure to connect the positive terminal first, then connect the negative terminal.

- Remove the spark plugs. Turn the engine a few times by putting the transmission in top gear and turning the rear wheel. Reinstall the spark plugs.
- Drain the engine oil thoroughly. Replace the oil filter with a new one and pour fresh oil as outlined in this manual.
- Adjust the pressure of tires as described in the TIRES section.
- Lubricate all places as instructed in this manual.
- Do the "Inspection Before Riding" as listed in this manual.



SPECIFICATIONS

DIMENSIONS AND DRY MASS

Overall length	2055 mm (80.9 in)
Overall width	715 mm (28.1 in)
Overall height	1150 mm (45.3 in)
Wheelbase	1400 mm (55.1 in)
Ground clearance	135 mm (5.3 in)
Seat height	825 mm (32.5 in)
Dry mass	161 kg (354 lbs)

ENGINE

Type	Four-stroke, liquid-cooled, DOHC
Number of cylinders	4
Bore	67.0 mm (2.638 in)
Stroke	42.5 mm (1.673 in)
Displacement	599 cm ³ (36.5 cu. in)
Compression ratio	12.5 : 1
Fuel system	Fuel injection
Air cleaner	Non-woven fabric element
Starter system	Electric
Lubrication system	Wet sump

TRANSMISSION

Clutch	Wet multi-plate type
Transmission	6-speed constant mesh
Gearshift pattern	1-down, 5-up
Primary reduction ratio	1.926 (79/41)
Gear ratios, Low	2.785 (39/14)
2nd	2.052 (39/19)
3rd	1.681 (37/22)
4th	1.450 (29/20)
5th	1.304 (30/23)
Top	1.181 (26/22)
Final reduction ratio	2.812 (45/16)
Drive chain	RK525SMOZ7, 110 links

CHASSIS

Front suspension	Telescopic, coil spring, oil damped
Rear suspension	Link type, coil spring, oil damped
Caster	23.2°
Trail	93 mm (3.7 in)
Steering angle	27° (right and left)
Turning radius	3.4 m (11.2 ft)
Front brake	Disk brake, twin
Rear brake	Disk brake
Front tire size	120/70 ZR17 M/C (58W), tubeless
Rear tire size	180/55 ZR17 M/C (73W), tubeless

ELECTRICAL

Ignition type	Electronic ignition (Transistorized)
Spark plug	NGK CR9E or DENSO U27ESR-N
Battery	12V 28.8 kC(8 Ah)/10 HR
Generator	Three-phase A.C. generator
Fuse	30/10/10/15/10/10/10A ... EU 30/15/10/15/10/10/10A ... Others
Headlight	12V 55W (H7) ... Upper 12V 60/55W (H4) ... Lower
Position light	12V 5W ... EU
Turn signal light	12V 18W
Brake light/Tailight	LED
Speedometer light	LED
Tachometer light	LED
Fuel indicator light	LED
Turn signal indicator light	LED
High beam indicator light	LED
Neutral indicator light	LED
Coolant temperature/	
Oil pressure indicator	LED
Fuel injection warning light	LED

CAPACITIES

Fuel tank, including reserve	17.0 L (4.5/3.7 US/Imp. gal)
Engine oil, oil change	2800 ml (3.0/2.5 US/Imp. qt)
with filter change	3100 ml (3.3/2.7 US/Imp. qt)
Coolant	3.0 L (3.2/2.6 US/Imp. qt)

NOISE CONTROL SYSTEM (AUSTRALIA ONLY)

TAMPERING WITH NOISE CONTROL SYSTEM PROHIBITED

Owners are warned that the law may prohibit:

- (a) The removal or rendering inoperative by any person other than for purposes of maintenance, repair or replacement, of any device or element of design incorporated into any new vehicle for the purpose of noise control prior to its sale or delivery to the ultimate purchaser or while it is in use; and
- (b) The use of the vehicle after such device or element of design has been removed or rendered inoperative by any person.

Prepared by

SUZUKI MOTOR CORPORATION

Motorcycle Service Department

November, 2003

Part No. 99011-29G50-01A

Printed in Japan

SUZUKI MOTOR CORPORATION



* 9 9 0 1 1 - 2 9 6 5 0 - 0 1 A *

K4

Part No. 99011-29G50-01A
November, 2003 (TK) EN
Printed in Japan